

## Strainer - Screen and supporting basket made of stainless steel

### ARI-Strainer -

#### Y-pattern with flanges

- TRB 801 Annex II No. 45 (except EN-JL1040)
- German TA - Luft TÜV-Test-No. 922-9204866

Grey cast iron  
SG iron  
Cast steel  
**Fig. 050**

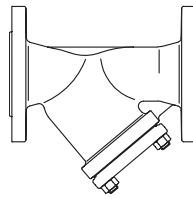

Page 2

### ARI-Strainer -

#### Y-pattern with flanges

- TRB 801 Annex II No. 45
- German TA - Luft TÜV-Test-No. 922-9204866

Stainless steel  
**Fig. 059**

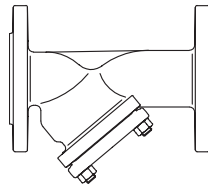

Page 3

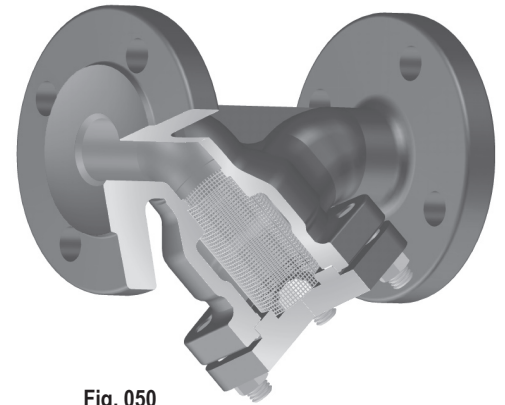

**Fig. 050**

### ARI-Strainer -

#### Y-pattern with butt weld ends

- TRB 801 Annex II No. 45
- German TA - Luft TÜV-Test-No. 922-9204866

Cast steel  
**Fig. 080**

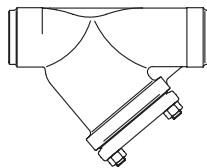

Page 4

#### Features:

- Screen and supporting basket made of stainless steel
- Screen from DN50 with reinforced ring
- Screen from DN150 with supporting basket
- Precise guidance of screen in cover and body

**Strainer - Y-pattern with flanges (Grey cast iron, SG iron, Cast steel)**

Figure	Nominal pressure	Material	Nominal diameter
10.050	PN6	EN-JL1040	DN15-200
12.050	PN16	EN-JL1040	DN15-300
22.050	PN16	EN-JS1049	DN15-300
23.050	PN25	EN-JS1049	DN15-150
34.050	PN25	1.0619+N	DN15-200
35.050	PN40	1.0619+N	DN15-200

A supporting basket is necessary, with higher differential pressures, dependent on clogging-up (DN >125 standard)

Test: • German TA - Luft TÜV-Test-No. 922-9204866

**Selection of possible applications**

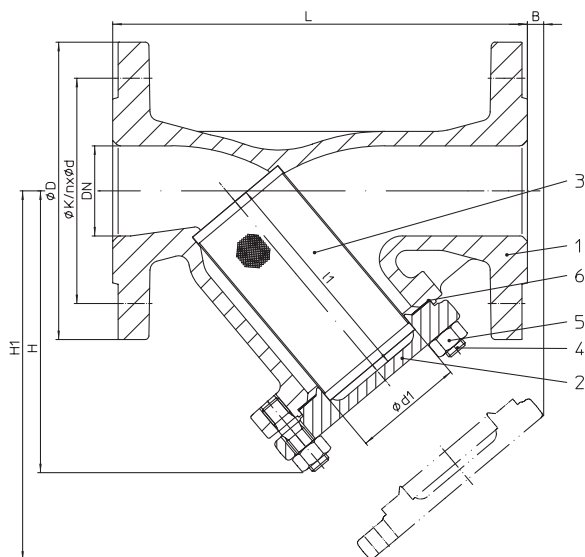
Industry, power stations, flue gas purification plant, vapour facilities, recycling facilities, shipbuilding, general plant manufacturing (other applications on request)

**Selection of possible flow media**

Steam, gases, liquids, etc. (other flow media on request)

**Parts**

Pos.	Description	Fig. 10./12.050	Fig. 22./23.050	Fig. 34./35.050
1	Body	EN-JL1040, EN-GJL-250	EN-JS1049, EN-GJS-400-18U-LT	GP240GH+N, 1.0619+N
2	Cover	DN ≤150: EN-JL1040, EN-GJL-250 DN >150: P265 GH, 1.0425	DN ≤65: EN-JS1049, EN-GJS-400-18U-LT DN >65: P265 GH, 1.0425	DN ≤65: P250 GH, 1.0460 DN >65: P265 GH, 1.0425
3	Screen *	X5CrNi18-10, 1.4301		
3.1	Supporting basket	DN >125: X5CrNi18-10, 1.4301		
4	Stud	25CrMo4, 1.7218		
5	Hexagon nut	C35E, 1.1181		
6	Gasket *	Pure graphite (CrNi laminated with graphite)		

\* Spare part

Information / restriction of technical rules need to be observed!

Operating instructions can be ordered by phone +49 (0)5207 / 994-0 or fax +49 (0)5207 / 994-158 or -159.

ARI-Valves of EN-JL1040 are not allowed to be operated in systems acc. to TRD 110.

A production allowance acc. to TRB 801 No. 45 exists (acc. to TRB 801 No. 45 EN-JL1040 is not allowed.)

The engineer, designing a system or a plant, is responsible for the selection of the correct valve.

**Dimensions**

	DN	15	20	25	32	40	50	65	80	100	125	150	200	250	300	350	400	500	
L	(mm)	130	150	160	180	200	230	290	310	350	400	480	600	730	850				
H	(mm)	90	100	115	125	150	160	180	215	235	275	305	390	540	680				
H1	(mm)	135	150	180	205	235	250	285	330	365	425	480	610	915	1110				
B	(mm)	10	10	25	35	45	45	25	40	55	65	50	80	230	350				
l1	(mm)	56	68	82	98	114	119	134	149	169	199	224	284	434	555				
Ød1	(mm)	23	28	36	42	50	61,5	78,5	89,5			160	210	258	308				
Standard screen	mesh width	(mm)	1	1	1	1	1	1,25	1,25	1,6	1,6	1,6	1,6	1,6	1,6				
	Kvs-value <sup>1)</sup>	(m³/h)	6,9	10,8	17,8	26,1	36,7	61	98,6	146	234	376	394	652	1225	1873			
	Zeta-value	--	1,7	2,2	1,9	2,4	3	2,7	2,9	3	2,9	2,7	4,5	5,5	4,1	3,7			
Fine screen	mesh width	(mm)	0,25	0,25	0,25	0,25	0,25	0,25	0,25	0,25	0,25	0,25	0,25	0,25	0,25				
	Kvs-value <sup>1)</sup>	(m³/h)	6,2	10,1	16,8	24,3	32,9	49,5	80,3	115	189	303	405	590	1231	1883			
	Zeta-value	--	1,9	2,4	2,2	2,8	3,7	4	4,9	4,9	4,4	4,2	4,3	6,7	4,1	3,6			
Ratio of the free screen surface area to the area of the nominal diameters.			10	8,4	8,3	7,1	6,8	5,2	4,4	3,7	2,8	2,7	2,4	2,3	2,7	2,9			
Zeta-value ... range of tolerance for Kvs-values acc. to VDI/VDE 2173																Standard-flange dimensions refer to page 6			
<sup>1)</sup> Kvs-values based upon clean screen !																			

Face-to-face dimension FTF series 1 according to DIN EN 558-1

**Weights**

Figure-No.	DN	15	20	25	32	40	50	65	80	100	125	150	200	250	300	350	400	500
10.050	(kg)	2,5	3	4,5	5,5	7	9	13	19	26	38	54	110	--	--			
12.050	(kg)	3	4	5	7	9	12	16	21	30	43	61	121	154	335			
22.050	(kg)	3,5	4	5,5	7	9	12	16	21	28	41	58	115	154	335			
23.050	(kg)	3,5	4	5,5	7	9	12	16	21	32	47	64	--	--	--			
34./35.050	(kg)	4	5	6	8	10	13	19	24,5	35	51	71	144	--	--			

**Strainer - Y-pattern with flanges (Stainless steel)**

Figure	Nominal pressure	Material	Nominal diameter
52.059	PN16	1.4408	DN15-200
54.059	PN25	1.4408	DN15-200
55.059	PN40	1.4408	DN15-200

A supporting basket is necessary, with higher differential pressures, dependent on clogging-up (DN >125 standard)

Test: • German TA - Luft TÜV-Test-No. 922-9204866

**Selection of possible applications**

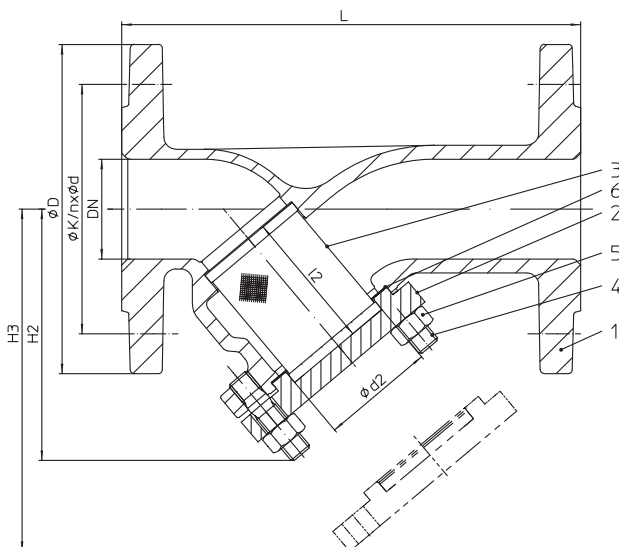
Recycling facilities, chemical industry, hospital technology, process water installations, installations with aggressive media (other applications on request)

**Selection of possible flow media**

Process water, aggressive media, etc. (other flow media on request)

**Parts**

Pos.	Description	Fig. 52./54./55.059
1	Body	GX5CrNiMo19-11-2, 1.4408
2	Cover	X6CrNiMoTi17-12-2, 1.4571
3	Screen *	X6CrNiMoTi17-12-2, 1.4571
3.1	Supporting basket	DN >125: X6CrNiMoTi17-12-2, 1.4571
4	Stud	A4-70
5	Hexagon nut	A4
6	Gasket *	Pure graphite (CrNi laminated with graphite)

\* Spare part

Information / restriction of technical rules need to be observed!

Operating instructions can be ordered by phone +49 (0)5207 / 994-0 or fax +49 (0)5207 / 994-158 or -159.

ARI-Valves of EN-JL1040 are not allowed to be operated in systems acc. to TRD 110.

A production allowance acc. to TRB 801 No. 45 exists

The engineer, designing a system or a plant, is responsible for the selection of the correct valve.

**Dimensions**

		DN	15	20	25	32	40	50	65	80	100	125	150	200	250	300	350	400	500
L		(mm)	130	150	160	180	200	230	290	310	350	400	480	600	on request				
H2		(mm)	94	94	102	102	123	126	148	170	202	285	320	417					
H3		(mm)	130	138	150	143	166	172	206	234	282	388	443	585					
l2		(mm)	48	48	57	57	68	70	85	97	112	138	169	230					
Ød2		(mm)	25	25	31	36	46	55,5	69,5	85,5			159	210					
Standard screen	mesh width	(mm)	1	1	1	1	1	1	1,25	1,25	1,6	1,6	1,6	1,6					
	Kvs-value <sup>1)</sup>	(m <sup>3</sup> /h)	6,9	10,8	17,8	26,1	36,7	61	98,6	146	234	376	394	652					
	Zeta-value	--	1,7	2,2	1,9	2,4	3	2,7	2,9	3	2,9	2,7	4,5	5,5					
Fine screen	mesh width	(mm)	0,25	0,25	0,25	0,25	0,25	0,25	0,25	0,25	0,25	0,25	0,25	0,25					
	Kvs-value <sup>1)</sup>	(m <sup>3</sup> /h)	6,2	10,1	16,8	24,3	32,9	49,5	80,3	115	189	303	405	590					
	Zeta-value	--	1,9	2,4	2,2	2,8	3,7	4	4,9	4,9	4,4	4,2	4,3	6,7					
Ratio of the free screen surface area to the area of the nominal diameters.			10	8,4	8,3	7,1	6,8	5,2	4,4	3,7	2,8	2,7	2,4	2,3					

Zeta-value ... range of tolerance for Kvs-values acc. to VDI/VDE 2173

Standard-flange dimensions refer to page 6

<sup>1)</sup> Kvs-values based upon clean screen !

Face-to-face dimension FTF series 1 according to DIN EN 558-1

**Weights**

Figure-No.	DN	15	20	25	32	40	50	65	80	100	125	150	200	250	300	350	400	500
52./54./55.059	(kg)	4	5	6	8	10	13	19	24,5	35,0	51	71	144	on request				

**Strainer - Y-pattern with butt weld ends (Cast steel)**

Figure	Nominal pressure	Material	Nominal diameter
35.080	PN40	1.0619+N	DN15-300
Butt weld ends according to DIN EN 12627 - 4 (refer to page 5)			
A supporting basket is necessary, with higher differential pressures, dependent on clogging-up (DN >125 standard)			
Test: • German TA - Luft TÜV-Test-No. 922-9204866			

**Selection of possible applications**

Industry, power stations, flue gas purification plant, vapour facilities, recycling facilities, shipbuilding, general plant manufacturing (other applications on request)

**Selection of possible flow media**

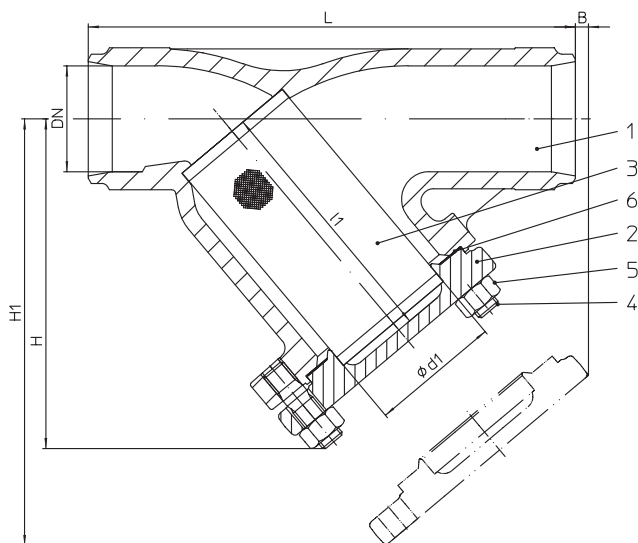
Steam, gases, liquids, etc. (other flow media on request)

**Parts**

Pos.	Description	Fig. 34./35.080
1	Body	GP240GH+N, 1.0619+N
2	Cover	DN ≤100: P250 GH, 1.0460 DN >100: P265 GH, 1.0425
3	Screen *	X5CrNi18-10, 1.4301
3.1	Supporting basket	DN >125: X5CrNi18-10, 1.4301
4	Stud	25CrMo4, 1.7218
5	Hexagon nut	C35E, 1.1181
6	Gasket *	Pure graphite (CrNi laminated with graphite)

**\* Spare part**

Information / restriction of technical rules need to be observed!

Operating instructions can be ordered by phone +49 (0)5207 / 994-0 or fax +49 (0)5207 / 994-158 or -159.

ARI-Valves of EN-JL1040 are not allowed to be operated in systems acc. to TRD 110.

A production allowance acc. to TRB 801 No. 45 exists

The engineer, designing a system or a plant, is responsible for the selection of the correct valve.

**Dimensions**

	DN	15	20	25	32	40	50	65	80	100	125	150	200	250	300	
L	(mm)	130	150	160	180	200	230	290	310	350	400	480	600	730	850	
H	(mm)	90	100	115	125	150	160	180	215	235	275	305	390	540	680	
H1	(mm)	135	150	180	205	235	250	285	330	365	425	480	610	915	1110	
B	(mm)	10	10	25	35	45	45	25	40	55	65	50	80	230	350	
I1	(mm)	56	68	82	98	114	119	134	149	169	199	224	284	434	555	
Ød1	(mm)	23	28	36	42	50	61,5	78,5	89,5	109,5	137,5	160	210	258	308	
Standard screen	mesh width	(mm)	1	1	1	1	1	1,25	1,25	1,6	1,6	1,6	1,6	1,6	1,6	
	Kvs-value <sup>1)</sup>	(m <sup>3</sup> /h)	6,9	10,8	17,8	26,1	36,7	61	98,6	146	234	376	394	652	1225	1873
	Zeta-value	--	1,7	2,2	1,9	2,4	3	2,7	2,9	3	2,9	2,7	4,5	5,5	4,1	3,7
Fine screen	mesh width	(mm)	0,25	0,25	0,25	0,25	0,25	0,25	0,25	0,25	0,25	0,25	0,25	0,25	0,25	
	Kvs-value <sup>1)</sup>	(m <sup>3</sup> /h)	6,2	10,1	16,8	24,3	32,9	49,5	80,3	115	189	303	405	590	1231	1883
	Zeta-value	--	1,9	2,4	2,2	2,8	3,7	4	4,9	4,9	4,4	4,2	4,3	6,7	4,1	3,6
Ratio of the free screen surface area to the area of the nominal diameters.			10	8,4	8,3	7,1	6,8	5,2	4,4	3,7	2,8	2,7	2,4	2,3	2,7	2,9

Zeta-value ... range of tolerance for Kvs-values acc. to VDI/VE 2173

<sup>1)</sup> Kvs-values based upon clean screen !

Face-to-face dimension FTF series 1 according to DIN EN 558-1

**Weights**

Figure-No.	DN	15	20	25	32	40	50	65	80	100	125	150	200	250	300
35.080	(kg)	2,5	3	3,5	4	5,5	7,5	12	15	23,5	33	49	106	135	240

L = Face-to-face dimension  
 Edge shaping acc. to DIN EN 25817

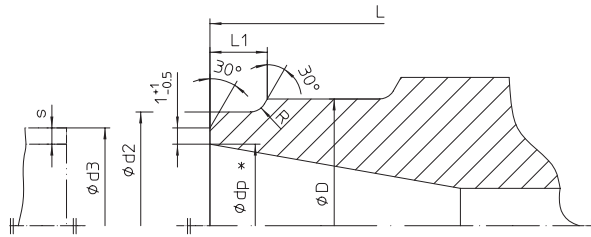

**Butt weld ends according to DIN EN 12627 - 4**

	DN	15	20	25	32	40	50	65	80	100	125	150	200	250	300	350	400
L	(mm)	130	150	160	180	200	230	290	310	350	400	480	600	730	850	980	1100
ØA	(mm)	22	28	35	44	50	62	77	91	117	144	172	223	278	329	362	413
ØB	(mm)	17,3	22,3	28,5	37,2	43,1	53,9	68,9	80,9	104,3	130,7	157,1	204,9	257,0	307,9	338,0	384,4
Ødi	(mm)	15	20	25	32	40	50	65	80	100	125	150	200	250	300	330	375
R	(mm)	3	3	3	3	3	3	3	3	3	3	3	5	5	5	5	5
L1	(mm)	10	10	10	10	10	10	10	12	14	18	20	20	25	33	45	45
Ød3	(mm)	21,3	26,9	33,7	42,4	48,3	60,3	76,1	88,9	114,3	139,7	168,3	219,1	273,0	323,9	355,6	406,4
s1	(mm)	2,0	2,3	2,6	2,6	2,6	3,2	2,9	4,0	5,0	4,5	5,6	7,1	8,0	8,0	8,8	11,0

Face-to-face dimension ETE series 1 according to DIN EN 12982.

Butt weld ends according to DIN EN 12627 - 4.

Weld joint according to DIN EN 29692 code numer 1.3.3.

The material used for ARI valves with butt weld ends are:  
 GP240GH+N, 1.0619+N acc. to DIN EN 10213-2.

Based on our experience we recommend electric welding process for connecting valves or strainers with tubes or with each other .

Lime based electrodes with an appropriate composite material should be used as filler material for welding.

Gas welding should be avoided.

Because of the different material compositions and wall thickness of the steam traps and the pipe gas welding shall not be applied. Quenching cracks and coarse grain structure may develop.

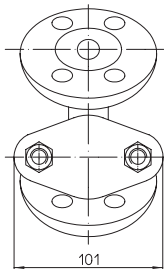

Only DN15: view on the cover flange  
 (not for stainless steel)

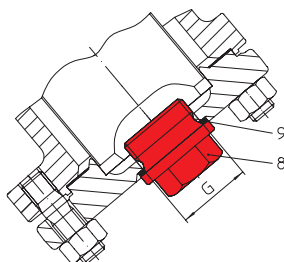

Bleed screw

DN	G
(mm)	(inch)
15-20	3/8
25-32	3/4
40-80	1
100-150	1 1/2
200-300	2
350-500	on request

Pos.	Description	Fig. 10./12.22./23./34./35.050; 34./35.080	Fig. 52./54./55.059;
8	Bleed screw	C35E, 1.1181	A4
9	Sealing ring	St	Aramid

**Standard-flange dimensions**

Flanges acc. to DIN EN 1092-1/-2 (Flangeholes / -thickness tol. acc. to DIN 2533/2544/2545)

DN		(mm)	15	20	25	32	40	50	65	80	100	125	150	200	250	300
PN6	ØD	(mm)	80	90	100	120	130	140	160	190	210	240	265	320	--	--
PN6	ØK	(mm)	55	65	75	90	100	110	130	150	170	200	225	280	--	--
PN6	n x Ød	(mm)	4x11	4x11	4x11	4x14	4x14	4x14	4x14	4x18	4x18	8x18	8x18	8x18	--	--
PN16	ØD	(mm)	95	105	115	140	150	165	185	200	220	250	285	340	405	460
PN16	ØK	(mm)	65	75	85	100	110	125	145	160	180	210	240	295	355	410
PN16	n x Ød	(mm)	4x14	4x14	4x14	4x18	4x18	4x18	4x18	8x18	8x18	8x18	8x22	12x22	12x26	12x26
PN25	ØD	(mm)	95	105	115	140	150	165	185	200	235	270	300	360	425	485
PN25	ØK	(mm)	65	75	85	100	110	125	145	160	190	220	250	310	370	430
PN25	n x Ød	(mm)	4x14	4x14	4x14	4x18	4x18	4x18	8x18	8x18	8x22	8x26	8x26	12x26	12x30	16x30
PN40	ØD	(mm)	95	105	115	140	150	165	185	200	235	270	300	375	450	515
PN40	ØK	(mm)	65	75	85	100	110	125	145	160	190	220	250	320	385	480
PN40	n x Ød	(mm)	4x14	4x14	4x14	4x18	4x18	4x18	8x18	8x18	8x22	8x26	8x26	12x30	12x33	16x33

**Pressure-temperature-ratings acc. to DIN EN 1092-2**

Material	PN		-60°C to <-10°C*	-10°C to 120°C	150°C	200°C	250°C	300°C	350°C	400°C	450°C
EN-JL1040	6	bar	--	6	5,4	4,8	4,2	3,6	--	--	--
EN-JL1040	16	bar	--	16	14,4	12,8	11,2	9,6	--	--	--
EN-JS1049	16	bar	on request	16	15,5	14,7	13,9	12,8	11,2	--	--
EN-JS1049	25	bar	on request	25	24,3	23	21,8	20	17,5	--	--

**Pressure-temperature-ratings acc. to DIN EN 1092-1**

Material	PN		-60°C to <-10°C*	-10°C to 50°C	100°C	150°C	200°C	250°C	300°C	350°C	400°C	450°C
1.0619+N	25	bar	18,7	25	23,3	21,7	19,4	17,8	16,1	15	14,4	13,9
1.0619+N	40	bar	30	40	37,3	34,7	30,2	28,4	25,8	24	23,1	22,2
1.4408	16	bar	16	16	14,9	13,5	12,4	11,7	11	10,7	10,2	--
1.4408	25	bar	25	25	23,3	21,1	19,4	18,3	17,2	16,7	16	--
1.4408	40	bar	40	40	37,3	33,8	31,1	29,3	27,6	26,7	25,6	--

Intermediate values for max. permissible operational pressures can be determined by linear interpolation of the given temperature / pressure chart.

\* Studs and nuts made of A4-70 (at temperatures below -10°C)

**Please indicate when ordering**

- Figure-No.
- Nominal pressure
- Nominal diameter
- Special design / accessories

**Example:**

Figure 35050; nominal pressure PN40; nominal diameter DN100; with bleed screw..

 Dimensions in mm  
 Weights in kg  
 1 bar  $\hat{=}$  10<sup>5</sup> Pa  $\hat{=}$  0,1 MPa  
 Kvs in m<sup>3</sup>/h

**Technology for the Future.**  
GERMAN QUALITY VALVES

ARI-Armaturen Albert Richter GmbH & Co. KG, D-33756 Schloß Holte-Stukenbrock,  
Tel. +49 52 07 / 994-0, Telefax +49 52 07 / 994-158 or 159 Internet: <http://www.ari-armaturen.com> E-mail: [info.vertrieb@ari-armaturen.com](mailto:info.vertrieb@ari-armaturen.com)