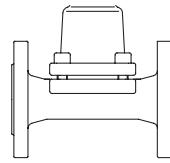


Bimetallic steam trap

**Bimetallic steam trap**

**PN16**

- with flanges (Fig. 600....1)
- union with butt weld ends (Fig. 600....5)



Grey cast iron  
Fig. 600

Page 2

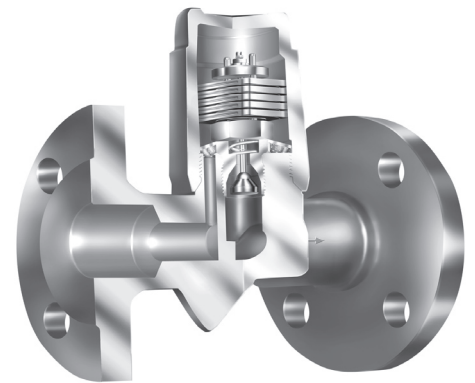
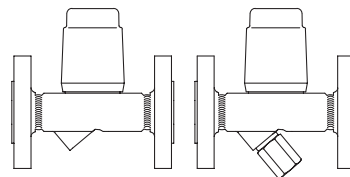


Fig. 600....1

**Bimetallic steam trap**

**PN40**

- with flanges (Fig. 600/601....1)
- with screwed sockets (Fig. 600/601....2)
- with socket weld ends (Fig. 600/601....3)
- with butt weld ends (Fig. 600/601....4)

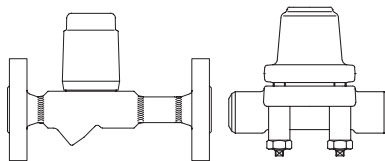


Forged steel DN15-25  
High temperature steel Page 4  
Stainless steel DN40-50  
Fig. 600/601 (Y) Page 6

**Bimetallic steam trap**

**PN63 / PN100**

- with flanges (Fig. 600....1)
- with socket weld ends (Fig. 600....3)
- with butt weld ends (Fig. 600....4)

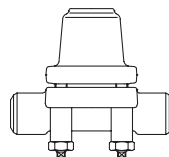


High temperature steel DN15-25  
Fig. 600 Page 8  
DN40-50  
Page 12

**High pressure bimetallic steam trap**

**PN160 / PN250**

- with flanges (Fig. 600....1)
- with socket weld ends (Fig. 600....3)
- with butt weld ends (Fig. 600....4)

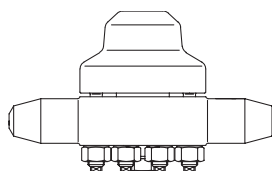


High temperature steel  
Fig. 600 Page 14

**High pressure bimetallic steam trap**

**PN320 / PN400 / PN630**

- with flanges (up to PN400) (Fig. 600....1)
- with socket weld ends (Fig. 600....3)
- with butt weld ends (Fig. 600....4)



High temperature steel  
Fig. 600 Page 16

**Features:**

- For discharging of slight to highly sub-cooled condensate
- Automatic air-venting during start up and operation of the plant
- Robust and resistant to water-hammer
- Integrated non return protection
- Design with internal strainer - Fig. 600  
Construction with outside strainer - Fig. 601 (Y)
- Optimized design for quick installation (PN40, DN15-25)
- Gasket-free sealing of the screwed cap (PN40 and PN63 with Cap, DN15-25)
- Installation in any position (except cover/screwed cap downwards)
- Subcooling of condensate is continuously adjustable (observe the operation instructions)
- The controller maybe changed without disturbing the pipe work

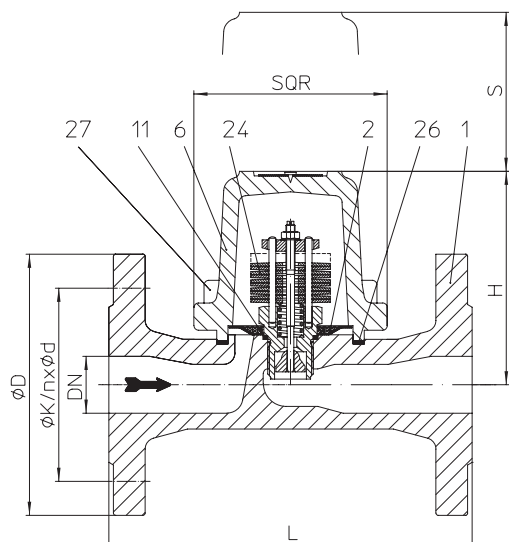
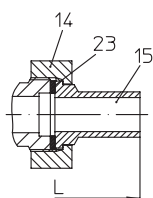
**Bimetallic steam trap (Grey cast iron)**


Fig. 600....1 with flanges


 Fig. 600....5  
 union with butt weld ends

- Thermostatic steam trap with non-corrosive and robust water hammer proof bimetallic controller
- Automatic air-venting during start up and operation of the plant
- Non return protection
- With inside strainer
- Installation in any position, except cover downwards
- Subcooling of condensate is continuously adjustable (observe the operation instructions)

**Operating limits**

Fig. 12.600	PN16 - EN-JL1040	
Operating pressure PS (bar-g)	12,8	9,6
Operating temperature TS (°C)	200	300
allowable differential pressure ΔPMX (bar):	13	
for controller:	R13	

**Types of connection**

Flanges ....1	PN16 acc. to DIN 2501
Union with butt weld nipples ....5	acc. to data sheet resp. customer request

Other types of connection on request.

Dimensions and Weights		Types of connection			
		Flanges		Union with butt weld nipples	
Nominal diameter	(mm) (inch)	25 1	50 2	15 1/2	20 3/4
L *	(mm)	160 / 180*	230 / 236*	190	190
H	(mm)	100	124	100	100
S	(mm)	70	70	70	70
SQR	(mm)	85	85	85	85
Weight approx.	(kg)	4,6	10	2,6	2,3

Standard-flange dimensions refer to page 19.

\* Face-to-face acc. to data sheet resp. customer request

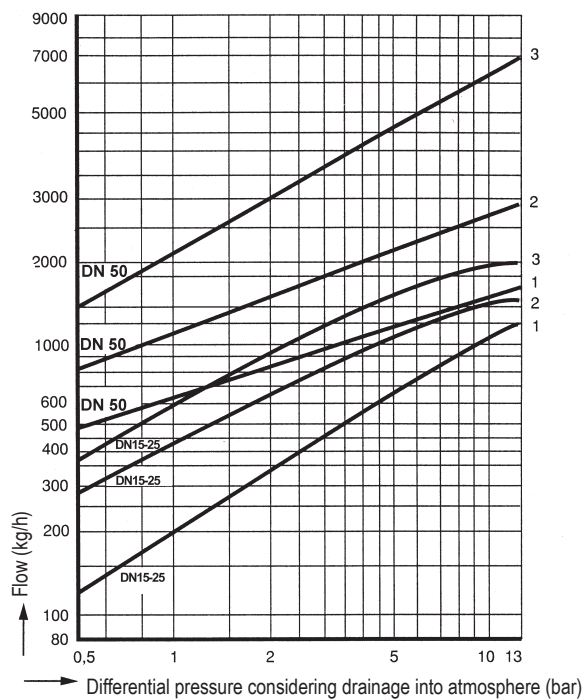
**Parts**

Pos.	Description	Fig. 12.600
1	Body	EN-GJL-250, EN-JL1040
2	Strainer *	X5CrNi18-10, 1.4301
6	Cover	EN-GJL-250, EN-JL1040
11	Sealing ring *	R-Cu99
14	Union nut	X14CrMoS17+QT, 1.4104+QT
15	Welding end	C 15, 1.0401
23	Sealing ring *	GRAPHIT (CrNi laminated with graphite)
24	Controller *	TB 102 / 85 (corrosion resistant bimetal)
26	Sealing ring *	GRAPHIT (CrNi laminated with graphite)
27	Cheese head screw	A2-70

\* Spare part

Information / restriction of technical rules need to be observed!

Operating instructions can be ordered by phone +49 (0)5207 / 994-0 or fax +49 (0)5207 / 994-158 or -159.

**Capacity chart**


The capacity chart shows the maximum flow at factory setting. (Other factory-settings for the sub-cooling on request.)

**Curve 1:**  
Maximum flow quantity of hot condensate at approx. 10 K below boiling temperature.

**Curve 2:**  
Maximum flow of sub-cooled condensate at approx. 30 K below boiling temperature (through back up of condensate).

**Curve 3:**  
Maximum flow quantity of cold condensate at about 20°C (during start-up of a cold installation).

**Bimetallic steam trap (Forged steel, High temperature steel, Stainless steel)**

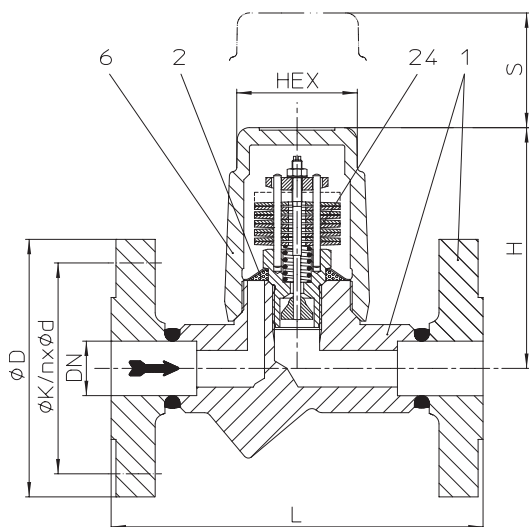


Fig. 600....1 with flanges

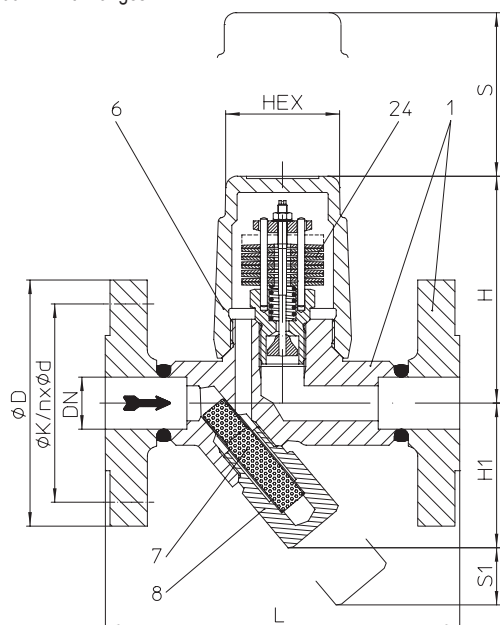


Fig. 601....1 with flanges

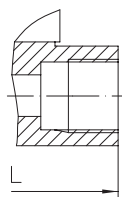


Fig. 600/601....2 with screwed sockets

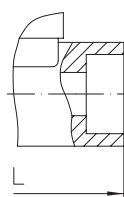


Fig. 600/601....3 with socket weld ends

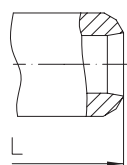


Fig. 600/601....4 with butt weld ends

- Thermostatic steam trap with non-corrosive and robust water hammer proof bimetallic controller
- Automatic air-venting during start up and operation of the plant
- Non return protection
- With inside strainer - Fig. 600  
With outside strainer - Fig. 601 (Y)
- Installation in any position, except screw cap downwards
- Subcooling of condensate is continuously adjustable (observe the operation instructions)
- Maintenance simplified due to screwed cap without sealing
- Available controllers:  
Controller R13 - to 13 bar inlet pressure  
Controller R22 - to 22 bar inlet pressure  
Controller R32 - to 32 bar inlet pressure
- Options: - Outside strainer with blow down valve (pos. 46)  
- Ball valve for blow down (pos. 56) with internal strainer (Observe operating and installation instructions!)

**Operating limits**

Fig. 45.600 / 45.601	PN40 - 1.0460		
Operating pressure PS (bar-g)	32	22	14,5
Operating temperature TS (°C)	250	385	450

allowable differential pressure ΔPMX (bar):	32	22	13
for controller:	R32	R22	R13

Fig. 85.600 / 85.601	PN40 - 16Mo3		
Operating pressure PS (bar-g)	35	32	28
Operating temperature TS (°C)	300	335	450

allowable differential pressure ΔPMX (bar):	32	22	13
for controller:	R32	R22	R13

Fig. 55.600 / 55.601	PN40 - 1.4541		
Operating pressure PS (bar-g)	32	22	
Operating temperature TS (°C)	350		400

allowable differential pressure ΔPMX (bar):	32	22	13
for controller:	R32	R22	R13

**Types of connection**

Flanges ....1	PN40 acc. to DIN 2501
Screwed sockets ....2	R- and NPT-thread acc. to DIN EN 10226-1
Socket weld ends ....3	acc. to DIN EN 12760
Butt weld ends ....4	acc. to DIN EN 12627

Other types of connection on request.

For ANSI versions refer to data sheet CONA®B-ANSI

Dimensions and Weights		Types of connection								
		Flanges			Screwed sockets Socket weld ends			Butt weld ends		
		15 1/2	20 3/4	25 1	15 1/2	20 3/4	25 1	15 1/2	20 3/4	25 1
Nominal diameter	(mm) (inch)									
L*	(mm)	150	150	160	95	95	95	250	250	250
H	(mm)	98	98	98	98	98	103	98	98	98
H1	(mm)	62	62	62	62	62	55	62	62	62
S	(mm)	70	70	70	70	70	70	70	70	70
S1	(mm)	30	30	30	30	30	30	30	30	30
HEX	(mm)	50	50	50	50	50	50	50	50	50
Weight approx.	(kg)	3,2	3,7	4,2	1,7	1,6	2,1	2,2	2,3	2,4

Standard-flange dimensions refer to page 19.

Larger nominal diameters refer to page 6.

\* Face-to-face acc. to data sheet resp. customer request

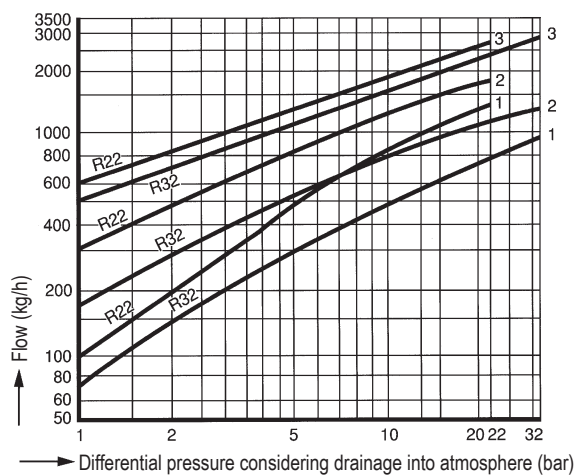
**Parts**

Pos.	Description	Fig. 45.600 / 45.601	Fig. 85.600 / 85.601	Fig. 55.600 / 55.601
1	Body	P250 GH, 1.0460	16Mo3, 1.5415	X6CrNiTi18-10, 1.4541
2	Strainer *	X5CrNi18-10, 1.4301		
6	Cap	P250 GH, 1.0460	16Mo3, 1.5415	X6CrNiTi18-10, 1.4541
7	Strainer screen *	X5CrNi18-10, 1.4301		
8	Strainer plug *	X6CrNiTi18-10, 1.4541		
24	Controller *	TB 102 / 85 (corrosion resistant bimetal)		
46	Blow down valve, cpl. *	X6CrNiTi18-10, 1.4541		
56	Ball valve for blow down (G 3/8") *	GX5CrNiMo19-11-2, 1.4408		

\* Spare part

Information / restriction of technical rules need to be observed!

Operating instructions can be ordered by phone +49 (0)5207 / 994-0 or fax +49 (0)5207 / 994-158 or -159.

**Capacity chart**


The capacity chart shows the maximum flow at factory setting. (Other factory-settings for the sub-cooling on request.)

**Curve 1:**

Maximum flow quantity of hot condensate at approx. 10 K below boiling temperature.

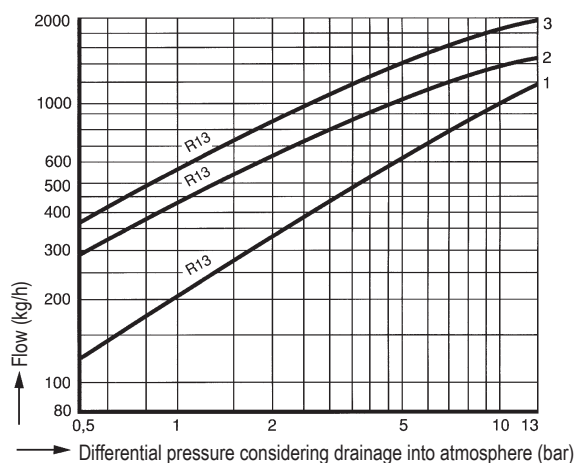
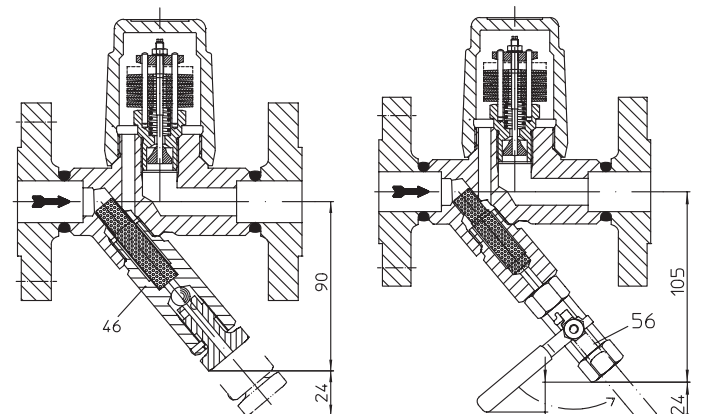
**Curve 2:**

Maximum flow of sub-cooled condensate at approx. 30 K below boiling temperature (through back up of condensate).

**Curve 3:**

Maximum flow quantity of cold condensate at about 20°C (during start-up of a cold installation).

The condensate temperature determines the opening of the controller. Capacity is increased with the sub-cooling temperature of the condensate.


**Options**


Outside strainer with blow down valve

Ball valve with adapter for blow down with internal strainer (restricted to 16 bar, 210°C)

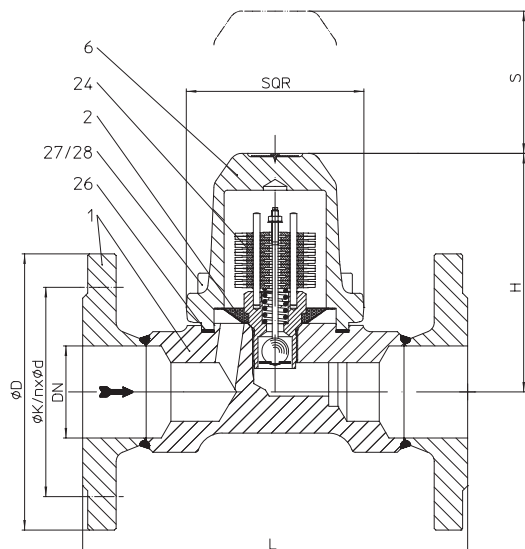
**Bimetallic steam trap (Forged steel, High temperature steel, Stainless steel)**


Fig. 600....1 with flanges

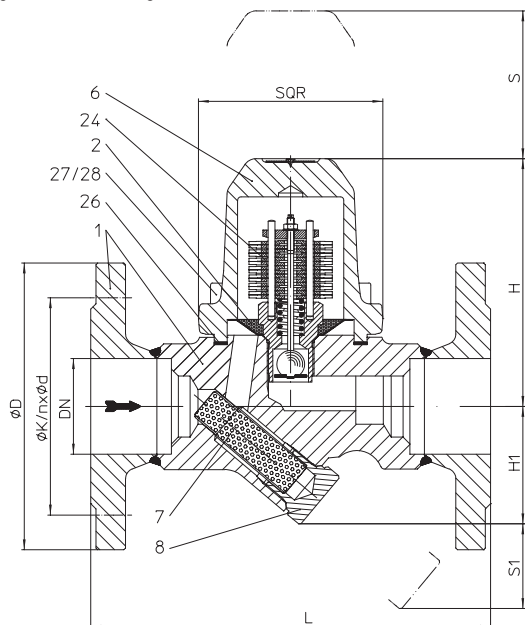


Fig. 601....1 with flanges

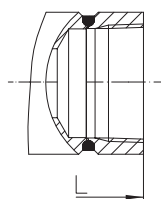


Fig. 600/601....2 with screwed sockets

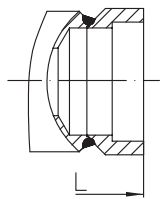


Fig. 600/601....3 with socket weld ends

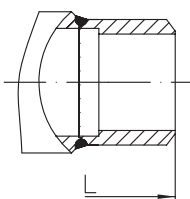


Fig. 600/601....4 with butt weld ends

- Thermostatic steam trap with non-corrosive and robust water hammer proof bimetallic controller
- Automatic air-venting during start up and operation of the plant
- Non return protection
- With inside strainer - Fig. 600  
With outside strainer - Fig. 601 (Y)
- Installation in any position, except cover downwards
- Subcooling of condensate is continuously adjustable (observe the operation instructions)
- The controller maybe changed without disturbing the pipe work
- Available controllers:  
Controller R13 - to 13 bar inlet pressure  
Controller R22 - to 22 bar inlet pressure  
Controller R32 - to 32 bar inlet pressure
- Options: - Outside strainer with blow down valve (pos. 46)  
- Ball valve for blow down (pos. 56) with internal strainer (Observe operating and installation instructions!)

**Operating limits**

Fig. 45.600 / 45.601	PN40 - 1.0460		
Operating pressure PS (bar-g)	32	22	14,5
Operating temperature TS (°C)	250	385	450

allowable differential pressure ΔPMX (bar):	32	22	13
for controller:	R32	R22	R13

Fig. 85.600 / 85.601	PN40 - 16Mo3		
Operating pressure PS (bar-g)	35	32	28
Operating temperature TS (°C)	300	335	450

allowable differential pressure ΔPMX (bar):	32	22	13
for controller:	R32	R22	R13

Fig. 55.601	PN40 - 1.4541		
Operating pressure PS (bar-g)	32	22	
Operating temperature TS (°C)	350	400	

allowable differential pressure ΔPMX (bar):	32	22	13
for controller:	R32	R22	R13

**Types of connection**

Flanges ....1	PN40	(acc. to DIN 2501)
Screwed sockets ....2	R- and NPT-thread	(acc. to DIN EN 10226-1)
Socket weld ends ....3	(acc. to DIN EN 12760)	
Butt weld ends ....4	(acc. to DIN EN 12627)	

Other types of connection on request.

For ANSI versions refer to data sheet CONA®B-ANSI

Dimensions and Weights		Types of connection					
		Flanges		Screwed sockets <sup>1)</sup> Socket weld ends		Butt weld ends	
		40 1 1/2	50 2	40 1 1/2	50 2	40 1 1/2	50 2
Nominal diameter	(mm) (inch)						
L*	(mm)	230	230	130 / 160 <sup>1)</sup>	210	250	250
H	(mm)	144	144	144	144	144	144
H1	(mm)	68	68	68	68	68	68
S	(mm)	90	90	90	90	90	90
S1	(mm)	50	50	50	50	50	50
SQR	(mm)	110	110	110	110	110	110
Weight approx.	(kg)	11,3	12,1	8	8	8,9	9,8

Standard-flange dimensions refer to page 19.

Smaller nominal diameters refer to page 4.

\* Face-to-face acc. to data sheet resp. customer request

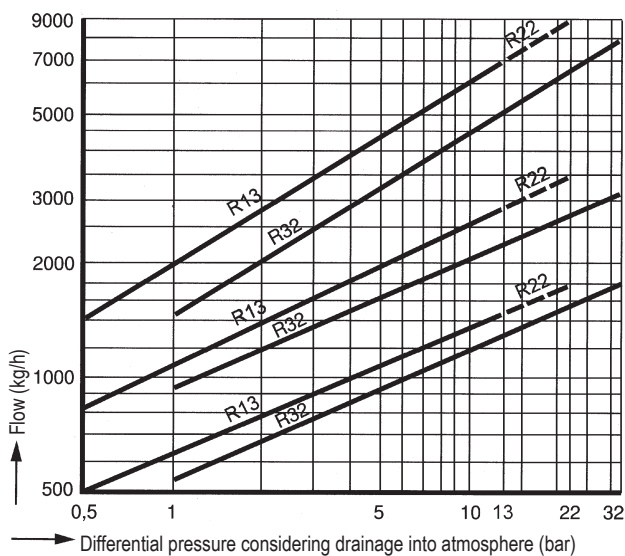
**Parts**

Pos.	Description	Fig. 45.600 / 45.601	Fig. 85.600 / 85.601	Fig. 55.600 / 55.601
1	Body	P250 GH, 1.0460	16Mo3, 1.5415	X6CrNiTi18-10, 1.4541
2	Strainer *	X5CrNi18-10, 1.4301		
6	Deckel	P250 GH, 1.0460	16Mo3, 1.5415	X6CrNiTi18-10, 1.4541
7	Strainer screen *	X5CrNi18-10, 1.4301		
8	Strainer plug *	X6CrNiTi18-10, 1.4541		
24	Controller *	TB 102 / 85 (corrosion resistant bimetal)		
26	Sealing ring *	Graphite (CrNi laminated with graphite)		
27	Cheese head screw	21CrMoV 5-7, 1.7709		
28	Hexagonal nut	21CrMoV 5-7, 1.7709		
46	Blow down valve, cpl. *	X6CrNiTi18-10, 1.4541		
56	Ball valve for blow down (G 3/8") *	GX5CrNiMo19-11-2, 1.4408		

\* Spare part

Information / restriction of technical rules need to be observed!

Operating instructions can be ordered by phone +49 (0)5207 / 994-0 or fax +49 (0)5207 / 994-158 or -159.

**Capacity chart**


The capacity chart shows the maximum flow at factory setting. (Other factory-settings for the sub-cooling on request.)

**Curve 1:**

Maximum flow quantity of hot condensate at approx. 15 K below boiling temperature.

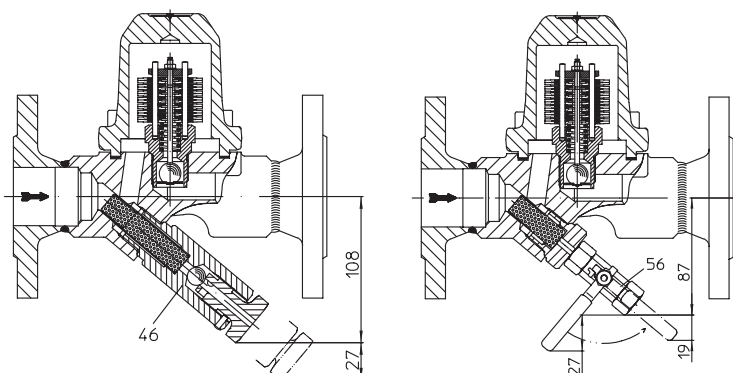
**Curve 2:**

Maximum flow of sub-cooled condensate at approx. 30 K below boiling temperature (through back up of condensate).

**Curve 3:**

Maximum flow quantity of cold condensate at about 20°C (during start-up of a cold installation).

The condensate temperature determines the opening of the controller. Capacity is increased with the sub-cooling temperature of the condensate.

**Options**


Outside strainer with blow down valve

Ball valve with adapter for blow down with internal strainer (restricted to 16 bar, 210°C)

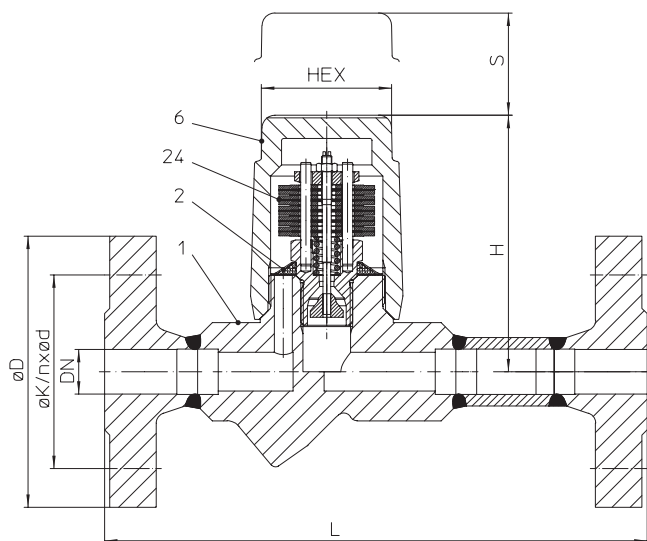
**Bimetallic steam trap (High temperature steel)**


Fig. 600....1 with flanges

- Thermostatic steam trap with non-corrosive and robust water hammer proof bimetallic controller
- Automatic air-venting during start up and operation of the plant
- Non return protection
- With inside strainer - Fig. 600
- Installation in any position, except screw cap downwards
- Subcooling of condensate is continuously adjustable (observe the operation instructions)
- Maintenance simplified due to screwed cap without sealing

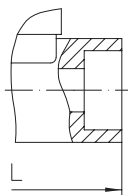
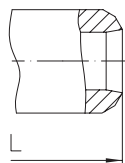
**Operating limits**

Fig. 86.600	PN63 - 16Mo3	
Operating pressure PS (bar-g)	46	45
Operating temperature TS (°C)	425	450
allowable differential pressure $\Delta$ PMX (bar):	46	
for controller:	R46	

**Types of connection**

Flanges ....1	PN63 acc. to DIN 2501
Socket weld ends ....3	acc. to DIN EN 12760
Butt weld ends ....4	acc. to DIN EN 12627

Other types of connection on request.

**For ANSI versions refer to data sheet CONA®B-ANSI**

 Fig. 600....3  
 with socket weld ends

 Fig. 600....4  
 with butt weld ends

Dimensions and Weights		Types of connection								
		Flanges			Socket weld ends			Butt weld ends		
Nominal diameter	(mm) (inch)	15 1/2	20 <sup>1)</sup> 3/4	25 1	15 1/2	20 3/4	25 1	15 1/2	20 3/4	25 1
L*	(mm)	210	210	230	95	95	95	250	250	250
H	(mm)	98	98	98	98	98	103	98	98	98
S	(mm)	70	70	70	70	70	70	70	70	70
HEX	(mm)	50	50	50	50	50	50	50	50	50
Weight approx.	(kg)	4,1	5,6	7	1,7	1,6	2,1	2,2	2,3	2,4

<sup>1)</sup> acc. to DIN EN 1092-1

Standard-flange dimensions refer to page 19.

\* Face-to-face acc. to data sheet resp. customer request

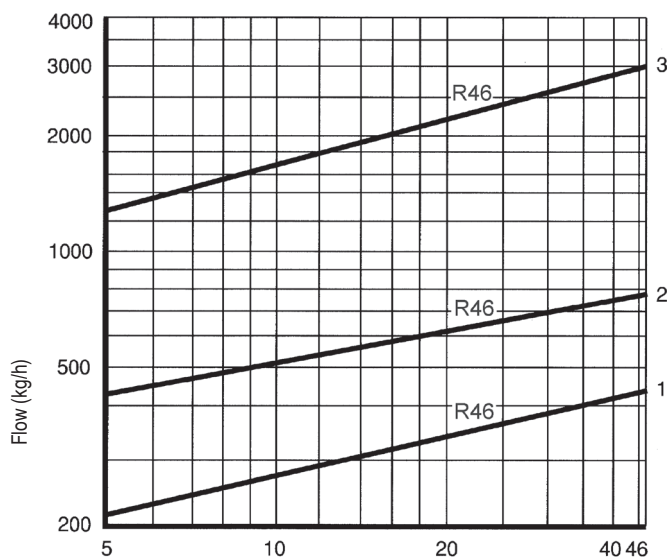
**Parts**

Pos.	Description	Fig. 86.600
1	Body	16Mo3, 1.5415
2	Strainer *	X5CrNi18-10, 1.4301
6	Cap	16Mo3, 1.5415
24	Controller *	TB 102 / 85 (corrosion resistant bimetal)
* Spare part		

Information / restriction of technical rules need to be observed!

Operating instructions can be ordered by phone +49 (0)5207 / 994-0 or fax +49 (0)5207 / 994-158 or -159.

**Capacity chart**



Differential pressure considering drainage into atmosphere (bar)

The capacity chart shows the maximum flow of hot and cold condensate at factory setting. For operating pressures below 5 bar, a correction of the factory-setting acc. to manufacturers information is recommended.)

**Curve 1:**

Maximum flow quantity of hot condensate at approx. 15 K below boiling temperature.

**Curve 2:**

Maximum flow of sub-cooled condensate at approx. 30 K below boiling temperature (through back up of condensate).

**Curve 3:**

Maximum flow quantity of cold condensate at about 20°C (during start-up of a cold installation).

The condensate temperature determines the opening of the controller. Capacity is increased with the sub-cooling temperature of the condensate.

**High pressure - Bimetallic steam trap (High temperature steel)**

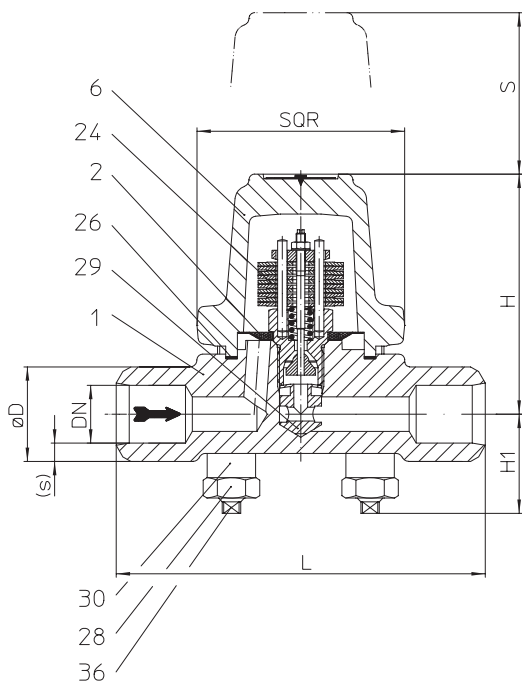


Fig. 600...4 with butt weld ends

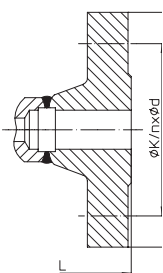


Fig. 600...1 with flanges

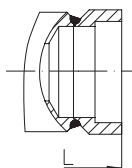


Fig. 600...3 with socket weld ends

- Thermostatic steam trap with non-corrosive and robust water hammer proof bimetallic controller
- Steam trap specially for high pressures
- Automatic air-venting during start up and operation of the plant
- Non return protection
- With inside strainer
- Installation in any position, except cover downwards
- Subcooling of condensate is continuously adjustable (observe the operation instructions)
- The controller maybe changed without disturbing the pipe work
- Controller at PN100 available for operating range:  
Controller R56 - to 56 bar inlet pressure  
Controller R90 - to 90 bar inlet pressure

**Operating limits**

Fig. 86.600	PN63 - 16Mo3		
Operating pressure PS (bar-g)	56	47	45
Operating temperature TS (°C)	300	400	450
allowable differential pressure ΔPMX (bar):	56		
for controller:	R56		

Fig. 87.600	PN100 - 16Mo3		
Operating pressure PS (bar-g)	90	56	27
Operating temperature TS (°C)	450	500	530
allowable differential pressure ΔPMX (bar):	56	90	
for controller:	R56	R90	

**Types of connection**

Flanges ....1	PN63 / PN100 acc. to DIN 2501
Socket weld ends ....3	acc. to DIN EN 12760
Butt weld ends ....4	acc. to DIN EN 12627

Other types of connection on request.

For ANSI versions refer to data sheet CONA®B-ANSI

Dimensions and Weights		Types of connection							
		Flanges		Socket weld ends			Butt weld ends		
Nominal diameter	(mm) (inch)	15 1/2	25 1	15 1/2	20 3/4	25 1	15 1/2	20 3/4	25 1
L*	(mm)	210	230	160	160	160	160	160	160
H	(mm)	104	104	104	104	104	104	104	104
H1	(mm)	42	42	42	42	42	42	42	42
S	(mm)	70	70	70	70	70	70	70	70
SQR	(mm)	90	90	90	90	90	90	90	90
Weight approx.	(kg)	6,2	9,3	4,6	4,5	4,4	4,6	4,5	4,4

Standard-flange dimensions refer to page 19.

Larger nominal diameters (PN63) refer to page 10.

\* Face-to-face acc. to data sheet resp. customer request

**Parts**

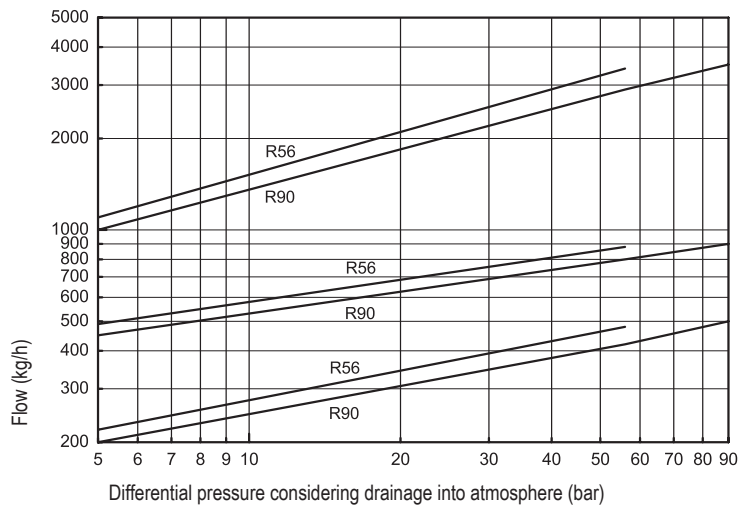
Pos.	Description	Fig. 86.600 / 87.600
1	Body	16Mo3, 1.5415
2	Strainer *	X5CrNi18-10, 1.4301
6	Cover	16Mo3, 1.5415
24	Controller *	TB 102 / 85 (corrosion resistant bimetal)
26	Sealing ring *	Graphite (CrNi laminated with graphite)
28	Hexagonal nut	21CrMoV 5-7, 1.7709
29	Erosion deflector *	X17CrNi16-2, 1.4057
30	Extension sleeve	21CrMoV 5-7, 1.7709
36	Stud	21CrMoV 5-7, 1.7709

\* Spare part

Information / restriction of technical rules need to be observed!

Operating instructions can be ordered by phone +49 (0)5207 / 994-0 or fax +49 (0)5207 / 994-158 or -159.

**Capacity chart**



The capacity chart shows the maximum flow of hot and cold condensate at factory setting. For operating pressures below 5 bar, a correction of the factory-setting acc. to manufacturers information is recommended.)

**Curve 1:**

Maximum flow quantity of hot condensate at approx. 15 K below boiling temperature.

**Curve 2:**

Maximum flow of sub-cooled condensate at approx. 30 K below boiling temperature (through back up of condensate).

**Curve 3:**

Maximum flow quantity of cold condensate at about 20°C (during start-up of a cold installation).

The condensate temperature determines the opening of the controller. Capacity is increased with the sub-cooling temperature of the condensate.

**High pressure - Bimetallic steam trap (High temperature steel)**

- Thermostatic steam trap with non-corrosive and robust water hammer proof bimetallic controller
- Automatic air-venting during start up and operation of the plant
- Non return protection
- With inside strainer
- Installation in any position, except cover downwards
- Subcooling of condensate is continuously adjustable (observe the operation instructions)
- The controller may be changed without disturbing the pipe work
- Available controllers:  
 Controller R56 - to 56 bar inlet pressure  
 Controller R32 - to 32 bar inlet pressure

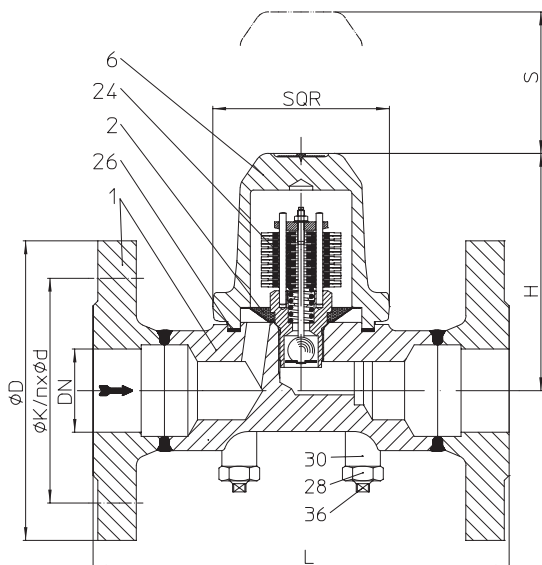

**Operating limits**

Fig. 86.600	PN63 - 16Mo3		
Operating pressure PS (bar-g)	56	50	45
Operating temperature TS (°C)	300	350	450
allowable differential pressure ΔPMX (bar):	56		32
for controller:	R56		R32

**Types of connection**

Flanges ....1	PN63 acc. to DIN 2501
Socket weld ends ....3	acc. to DIN EN 12760
Butt weld ends ....4	acc. to DIN EN 12627

Other types of connection on request.

For ANSI versions refer to data sheet CONA®B-ANSI

Fig. 600....2 with flanges

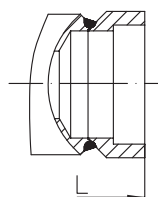


Fig. 600....3  
with socket weld ends

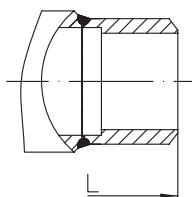


Fig. 600....4  
with butt weld ends

Dimensions and Weights		Types of connection					
		Flanges		Socket weld ends		Butt weld ends	
Nominal diameter	(mm) (inch)	40 1 1/2	50 2	40 1 1/2	50 2	40 1 1/2	50 2
L*	(mm)	260	300	130	210	250	250
H	(mm)	144	144	144	144	144	144
S	(mm)	90	90	90	90	90	90
SQR	(mm)	110	110	110	110	110	110
Weight approx.	(kg)	13,3	14,1	8	8	8,9	9,8

Standard-flange dimensions refer to page 19.

Smaller nominal diameters refer to page 8.

\* Face-to-face acc. to data sheet resp. customer request

**Parts**

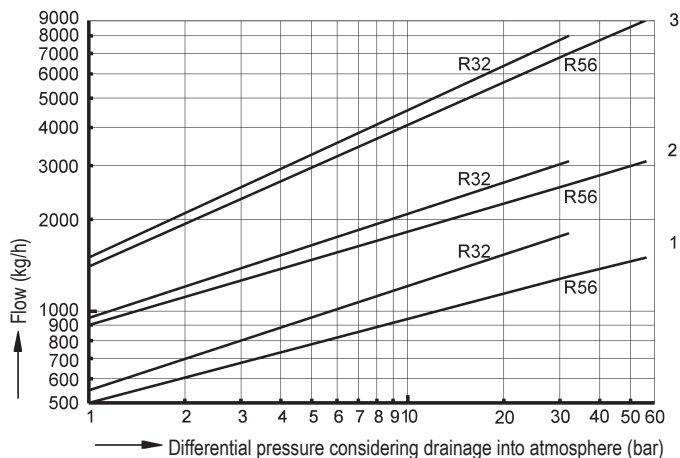
Pos.	Description	Fig. 86.600
1	Body	16Mo3, 1.5415
2	Strainer *	X5CrNi18-10, 1.4301
6	Cover	16Mo3, 1.5415
24	Controller *	TB 102 / 85 (corrosion resistant bimetal)
26	Sealing ring *	Graphite (CrNi laminated with graphite)
28	Hexagonal nut (TF M12)	21CrMoV 5-7, 1.7709
30	Extension sleeve	21CrMoV 5-7, 1.7709
36	Stud (L M12)	21CrMoV 5-7, 1.7709

\* Spare part

Information / restriction of technical rules need to be observed!

Operating instructions can be ordered by phone +49 (0)5207 / 994-0 or fax +49 (0)5207 / 994-158 or -159.

**Capacity chart**



The capacity chart shows the maximum flow at factory setting. For operating pressures below 5 bar, a correction of the factory-setting acc. to manufacturers information is recommended.)

**Curve 1:**  
Maximum flow quantity of hot condensate at approx. 15 K below boiling temperature.

**Curve 2:**  
Maximum flow of sub-cooled condensate at approx. 30 K below boiling temperature (through back up of condensate).

**Curve 3:**  
Maximum flow quantity of cold condensate at about 20°C (during start-up of a cold installation).

The condensate temperature determines the opening of the controller. Capacity is increased with the sub-cooling temperature of the condensate.

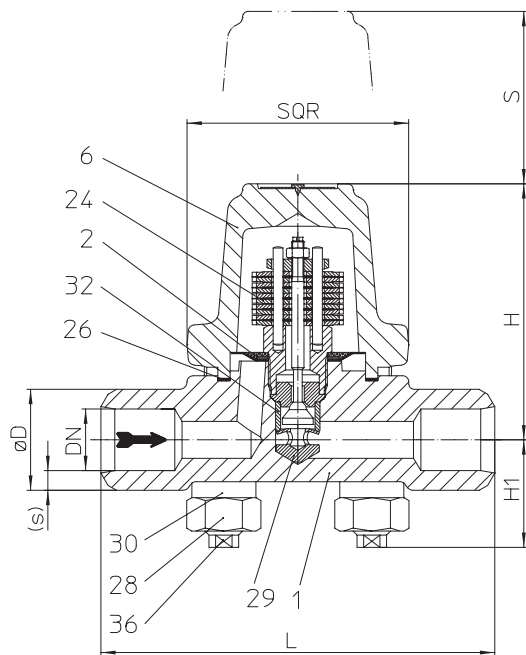
**High pressure - Bimetallic steam trap (High temperature steel)**


Fig. 600...4 with butt weld ends

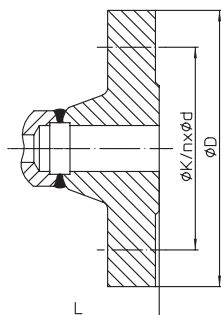


Fig. 600...1 with flanges

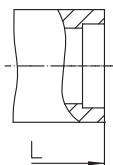


Fig. 600...3 with socket weld ends

- Thermostatic steam trap with non-corrosive and robust water hammer proof bimetallic controller
- **Steam trap specially for high pressures**
- Automatic air-venting during start up and operation of the plant
- Non return protection
- With inside strainer
- Installation in any position, except cover downwards
- Subcooling of condensate is continuously adjustable (observe the operation instructions)
- The controller maybe changed without disturbing the pipe work

**Operating limits**

Fig. 88.600	PN160 - 13CrMo4-5			
Operating pressure PS (bar-g)	153	100	62	35
Operating temperature TS (°C)	350	510	530	550

allowable differential pressure $\Delta$ PMX (bar):	110
for controller:	R130

Fig. 89.600	PN250 - 10CrMo9-10			
Operating pressure PS (bar-g)	184	154	108	81
Operating temperature TS (°C)	500	510	530	550

allowable differential pressure $\Delta$ PMX (bar):	154
for controller:	R150

**Types of connection**

Flanges ....1	PN160 / PN250 acc. to DIN 2501
Socket weld ends ....3	acc. to DIN EN 12760
Butt weld ends ....4	acc. to DIN EN 12627

Other types of connection on request.

**For ANSI versions refer to data sheet CONA®B-ANSI**

Dimensions and Weights		Types of connection							
		Flanges		Socket weld ends			Butt weld ends		
Nominal diameter	(mm) (inch)	15 1/2	25 1	15 1/2	20 3/4	25 1	15 1/2	20 3/4	25 1
L*	(mm)	210	230	160	160	160	160	160	160
H	(mm)	104	104	104	104	104	104	104	104
H1	(mm)	42	42	42	42	42	42	42	42
S	(mm)	70	70	70	70	70	70	70	70
SQR	(mm)	90	90	90	90	90	90	90	90
Weight approx.	(kg)	6,4	9,6	4,8	4,7	4,6	4,8	4,7	4,6

Standard-flange dimensions refer to page 19.

\* Face-to-face acc. to data sheet resp. customer request

**Parts**

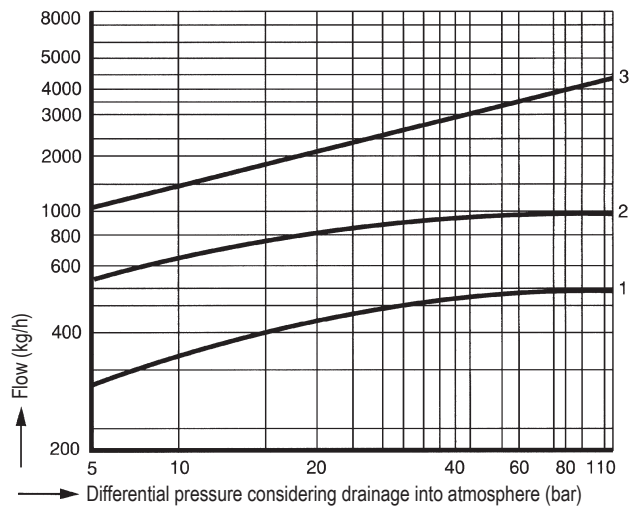
Pos.	Description	Fig. 88.600	Fig. 89.600
1	Body	13CrMo4-5, 1.7335	10CrMo9-10, 1.7380
2	Strainer *	X5CrNi18-10, 1.4301	
6	Cover	13CrMo4-5, 1.7335	10CrMo9-10, 1.7380
24	Controller *	TB 102 / 85 (corrosion resistant bimetal)	
26	Sealing ring *	Graphite (CrNi laminated with graphite)	
28	Hexagonal nut	X22CrMoV12-1, 1.4923	
29	Erosion deflector *	X17CrNi16-2, 1.4057	
30	Extension sleeve	X22CrMoV12-1, 1.4923	
32	Clamping sleeve *	X17CrNi16-2, 1.4057	
36	Stud	X22CrMoV12-1, 1.4923	

\* Spare part

Information / restriction of technical rules need to be observed!

Operating instructions can be ordered by phone +49 (0)5207 / 994-0 or fax +49 (0)5207 / 994-158 or -159.

**Capacity chart PN160**



The capacity chart shows the maximum flow at factory setting. For operating pressures below 15 bar, a correction of the factory-setting acc. to manufacturers information is recommended.)

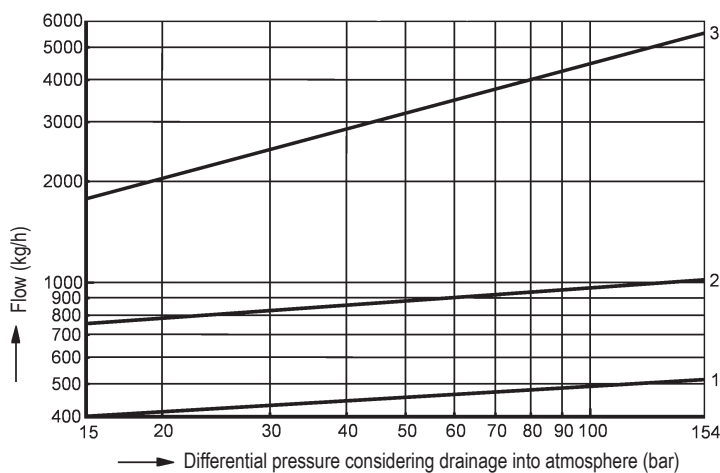
**Curve 1:**  
Maximum flow quantity of hot condensate at approx. 10 K below boiling temperature.

**Curve 2:**  
Maximum flow of sub-cooled condensate at approx. 30 K below boiling temperature (through back up of condensate).

**Curve 3:**  
Maximum flow quantity of cold condensate at about 20°C (during start-up of a cold installation).

The condensate temperature determines the opening of the controller. Capacity is increased with the sub-cooling temperature of the condensate.

**Capacity chart PN250**



**High pressure - Bimetallic steam trap (High temperature steel)**

- Thermostatic steam trap with non-corrosive and robust water hammer proof bimetallic controller
- **Steam trap specially for high pressures**
- Automatic air-venting during start up and operation of the plant
- Non return protection
- With inside strainer
- Installation in any position, except cover downwards
- Subcooling of condensate is continuously adjustable (observe the operation instructions)
- The controller maybe changed without disturbing the pipe work

**Operating limits**

Fig. 8a.600	PN320 - 10CrMo9-10			
Operating pressure PS (bar-g)	200	139	121	104
Operating temperature TS (°C)	510	530	540	550

allowable differential pressure ΔPMX (bar):	200			
for controller:	R270			

Fig. 8b.600	PN400 - 10CrMo9-10			
Operating pressure PS (bar-g)	250	174	151	130
Operating temperature TS (°C)	510	530	540	550

allowable differential pressure ΔPMX (bar):	250			
for controller:	R270			

Fig. 8c.600	PN630 - 10CrMo9-10			
Operating pressure PS (bar-g)	270	250	216	162
Operating temperature TS (°C)	547	550	560	580

allowable differential pressure ΔPMX (bar):	270			
for controller:	R270			

Fig. 8c.600	PN630 - X10CrMoVNb9-1			
Operating pressure PS (bar-g)	298	270	205	130
Operating temperature TS (°C)	550	581	590	600

allowable differential pressure ΔPMX (bar):	270			
for controller:	R270			

Fig. 8c.600	PN630 - X11CrMoWVNb9-1-1			
Operating pressure PS (bar-g)	300	270	250	180
Operating temperature TS (°C)	580	592	600	630

allowable differential pressure ΔPMX (bar):	270			
for controller:	R270			

**Types of connection**

Flanges ....1	PN320 / PN400 acc. to DIN 2501
Socket weld ends ....3	acc. to DIN EN 12670
Butt weld ends ....4	acc. to DIN EN 12627)

Other types of connection on request.

For ANSI versions refer to data sheet CONA®B-ANSI

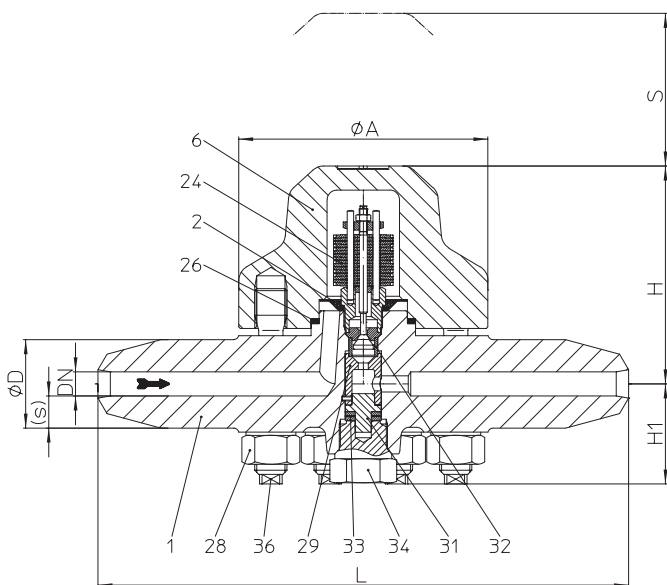


Fig. 600...4 with butt weld ends

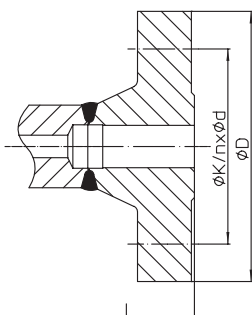


Fig. 600...1 (PN400) with flanges

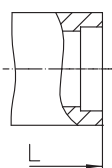


Fig. 600...3 with socket weld ends

Dimensions and Weights		Types of connection					
		Flanges		Socket weld ends		Butt weld ends	
Nominal diameter	(mm) (inch)	15 1/2	25 1	15 1/2	25 1	15 1/2	25 1
L*	(mm)	435	470	330	330	330	330
H	(mm)	135	135	135	135	135	135
H1	(mm)	63	63	63	63	63	63
S	(mm)	95	95	95	95	95	95
A	(mm)	155	155	155	155	155	155
Weight approx.	(kg)	27	33	20	19	20	19

Standard-flange dimensions refer to page 19.

\* Face-to-face acc. to data sheet resp. customer request

**Parts**

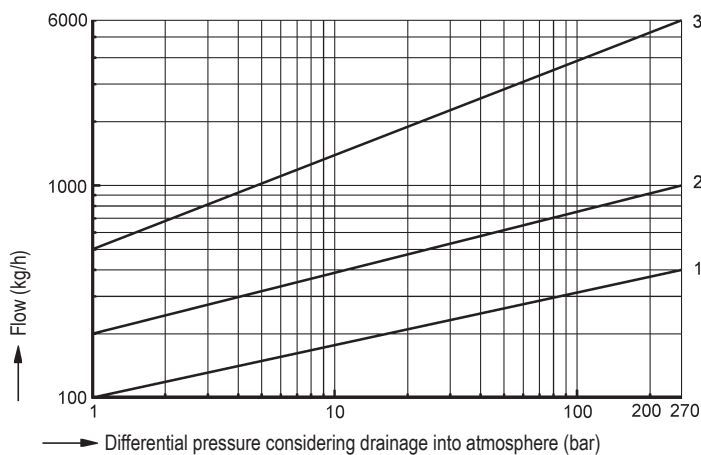
Pos.	Description	Fig. 8a.600 / 8b.600 / 8c.600	Fig. 8c.600	Fig. 8c.600
1	Body	10CrMo9-10, 1.7380	X10CrMoVNb9-1, 1.4903	X11CrMoWVNb9-1-1, 1.4905
2	Strainer *	X5CrNi18-10, 1.4301		
6	Cover	10CrMo9-10, 1.7380	X10CrMoVNb9-1, 1.4903	X11CrMoWVNb9-1-1, 1.4905
24	Controller *	TB 102 / 85 (corrosion resistant bimetal)		
26	Sealing ring *	Graphite / 1.4541 (Spiral-wound gasket)		
28	Hexagonal nut	X22CrMoV12-1, 1.4923		
29	Erosion deflector *	X39CrMo17-1+QT, 1.4122+QT		
31	Baffle straightener *	X39CrMo17-1+QT, 1.4122+QT		
32	Clamping sleeve *	X17CrNi16-2, 1.4057		
33	Lock washer	X5CrNi18-10, 1.4301		
34	Service screw	10CrMo9-10, 1.7380		
36	Stud	X22CrMoV12-1, 1.4923		

\* Spare part

Information / restriction of technical rules need to be observed!

Operating instructions can be ordered by phone +49 (0)5207 / 994-0 or fax +49 (0)5207 / 994-158 or -159.

**Capacity chart**



The capacity chart shows the maximum flow at factory setting. For operating pressures below 15 bar, a correction of the factory-setting acc. to manufacturers information is recommended.)

**Curve 1:**

Maximum flow quantity of hot condensate at approx. 10 K below boiling temperature.

**Curve 2:**

Maximum flow of sub-cooled condensate at approx. 30 K below boiling temperature (through back up of condensate).

**Curve 3:**

Maximum flow quantity of cold condensate at about 20°C (during start-up of a cold installation).

The condensate temperature determines the opening of the controller. Capacity is increased with the sub-cooling temperature of the condensate.

**Informations about pipe welding**

**Welding groove acc. to DIN 2559**

The material used for ARI valves with butt weld ends are:	1.0619+N	GP240GH+N acc. to DIN EN 10213-2
	1.0460	P250GH acc. to DIN EN 10222-2
	1.0401	C15 acc. to DIN 17210
	1.5415	16Mo3 acc. to DIN EN 10028
	1.4541	X6CrNiTi18-10 acc. to DIN EN 10088
	1.7335	13CrMo4-5 acc. to DIN EN 10028
	1.7380	10CrMo 9-10 acc. to DIN EN 10028
	1.4903	X10CrMoVNb 91 acc. to VdTÜV Data sheet 511/3 (06.99)
	1.4905	X11CrMo WVNb 9-1-1 acc. to VdTÜV Data sheet 522/3 (06.99)

Due to our experience, we recommend to apply an electric welding process.

Because of the different material compositions and wall thickness of the steam traps and the pipe gas welding shall not be applied. Quenching cracks and coarse grain structure may develop.

On bimetallic steam traps face-to-face of 95 mm or less, the bimetallic controller has to be disassembled prior to welding. After the traps have cooled down to the ambient temperature the bimetallic controller shall be fitted again into the body.

Steam traps with socket-weld ends shall only be welded by arc welding (welding process 111 acc. to DIN EN 24063).

If during the time of warranty others than the manufacturer or by the manufacturer authorized persons are interfering in the product and/or the setting, the right of claim for warranty will lapse!

**Selection criteria:**

- |                               |  |
|-------------------------------|--|
| - Steam pressure              | - Pipe-connection                            |
| - Back pressure               | - Controller                                 |
| - quantity of condensate      | - Material                                   |
| - Nominal diameter / pressure | - Place of service or kind of steam consumer |

**Example for order data:**

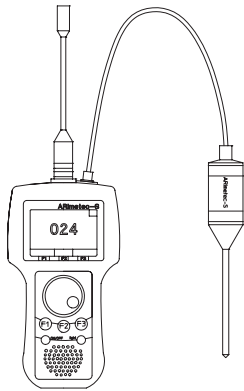
=> Bimetallic steam trap CONA® B,  
 Fig. 600, PN40, DN15, 1.0460, Controller R22, with flanges, Face-to-face dimension 150 mm

Dimensions in mm resp. inch Weights in kg 1 bar $\hat{=}$ 10 <sup>5</sup> Pa $\hat{=}$ 0,1 MPa Kvs in m <sup>3</sup> /h 1 bar $\hat{=}$ 14,5 psi 1 inch $\hat{=}$ 25,4 mm
--

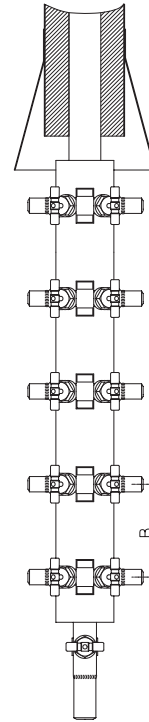
**Standard-flange dimensions**

Flanges according to DIN 2501 (\* PN63 DN20 acc. to DIN EN 1092-1)

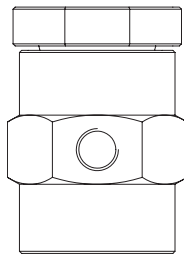
DN		(mm)	15	20	25	32	40	50
PN16	ØD	(mm)	95	105	115	140	150	165
PN16	ØK	(mm)	65	75	85	100	110	125
PN16	n x Ød	(mm)	4 x 14	4 x 14	4 x 14	4 x 18	4 x 18	4 x 18
PN40	ØD	(mm)	95	105	115	140	150	165
PN40	ØK	(mm)	65	75	85	100	110	125
PN40	n x Ød	(mm)	4 x 14	4 x 14	4 x 14	4 x 18	4 x 18	4 x 18
PN63	ØD	(mm)	105	105 *	140	--	170	180
PN63	ØK	(mm)	75	75 *	100	--	125	135
PN63	n x Ød	(mm)	4 x 14	4 x 14 *	4 x 18	--	4 x 22	4 x 22
PN100	ØD	(mm)	105	--	140	--	--	--
PN100	ØK	(mm)	75	--	100	--	--	--
PN100	n x Ød	(mm)	4 x 14	--	4 x 18	--	--	--
PN160	ØD	(mm)	130	--	150	--	--	--
PN160	ØK	(mm)	75	--	100	--	--	--
PN160	n x Ød	(mm)	4 x 14	--	4 x 18	--	--	--
PN250	ØD	(mm)	130	--	150	--	--	--
PN250	ØK	(mm)	90	--	105	--	--	--
PN250	n x Ød	(mm)	4 x 18	--	4 x 22	--	--	--
PN320	ØD	(mm)	130	--	160	--	--	--
PN320	ØK	(mm)	90	--	115	--	--	--
PN320	n x Ød	(mm)	4 x 18	--	4 x 22	--	--	--
PN400	ØD	(mm)	145	--	180	--	--	--
PN400	ØK	(mm)	100	--	130	--	--	--
PN400	n x Ød	(mm)	4 x 22	--	4 x 26	--	--	--



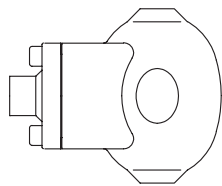
Multifunction tester **ARImetec<sup>®</sup>-S**



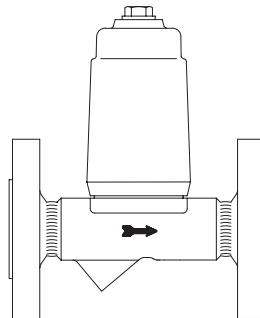
Condensate collection (B = 160), steam distribution (B = 120)  
**CODI<sup>®</sup>S** with gland packing Fig. 671/672;  
**CODI<sup>®</sup>B** with bellows seal, maintenance-free Fig. 675/676



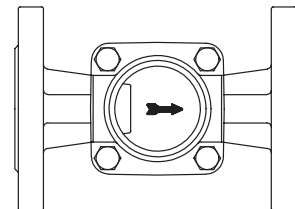
Vacuum breaker Fig. 655



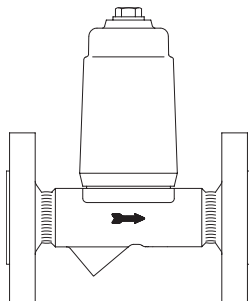
Automatic air vent for liquid systems  
Fig. 656



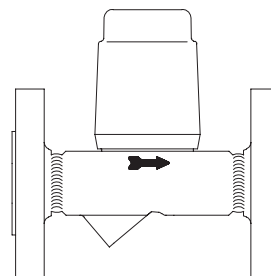
Condensate discharge temperature limiter  
Fig. 645/647



Flow indicator  
Fig. 660/661



Return temperature limiter Fig. 650



Liquid drainer Fig. 665

(Further informations about the accessories can be found in the appropriate data sheets.)