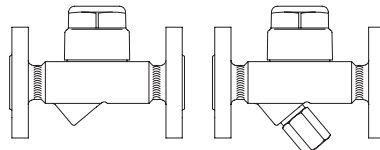


Thermodynamic steam trap

Thermodynamic steam trap

PN40

- with flanges (Fig. 640/641....1)
- with screwed sockets (Fig. 640/641....2)
- with socket weld ends (Fig. 640/641....3)
- with butt weld ends (Fig. 640/641....4)



Forged steel
High temperature steel
Stainless steel

Fig. 640/641 (Y)

Page 2

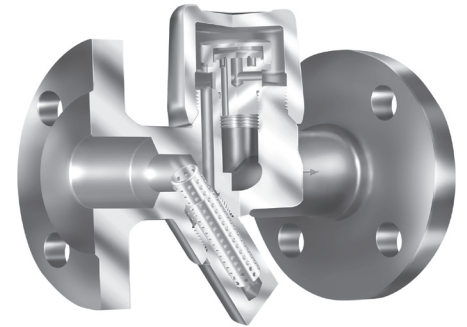
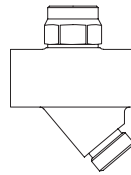


Fig. 641....1

Thermodynamic steam trap

PN63

- with screwed sockets (Fig. 641....2)
- with socket weld ends (Fig. 641....3)



Stainless steel
BR641 (Y)

Page 4

Features:

- For discharging of slight to highly sub-cooled condensate
- Intermittent mode of operation
- Robust and resistant to water-hammer
- Integrated non return protection
- Constructions:
 - with inside strainer - Fig. 640
 - with outside strainer - Fig. 641 (Y)
- Optimized design for quick installation
- Gasket-free sealing of the screwed cap
- Installation in any position
- Heat chamber minimizes the impact of weather conditions on the trap's performance (PN40 DN15-25)
- Replaceable controller-unit

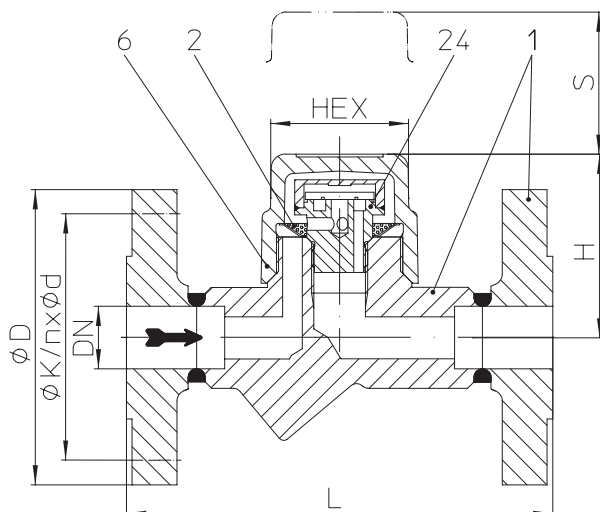
Thermodynamic steam trap (Forged steel, High temperature steel, Stainless steel)


Fig. 640....1 with flanges

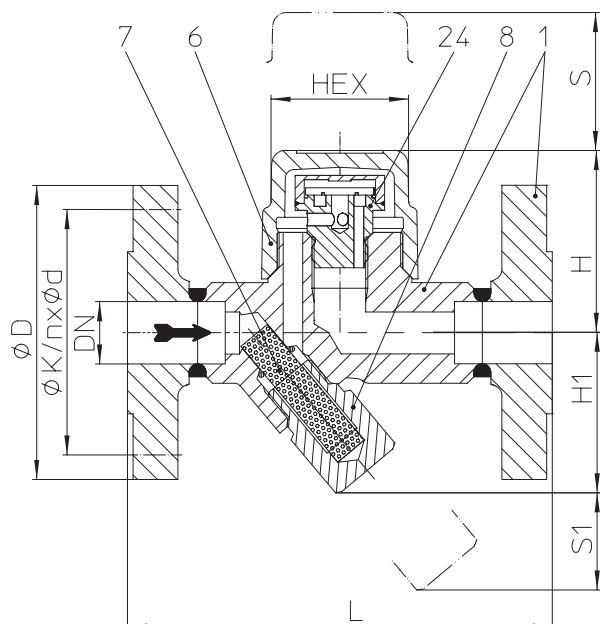


Fig. 641....1 with flanges

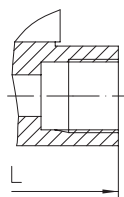


Fig. 640/641....2 with screwed sockets

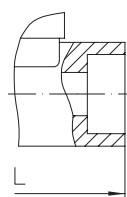


Fig. 640/641....3 with socket weld ends

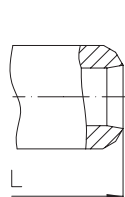


Fig. 640/641....4 with butt weld ends

- Thermodynamic steam trap with replaceable controller-unit and cap with heat chamber which minimize the effects from the weather conditions to the function of the trap such as low ambient temperatures, rain, wind, etc..
- Intermittent mode of operation
- Heat chamber minimizes the impact of weather conditions on the trap's performance
- Robust and resistant to water-hammer
- Integrated non return protection
- With inside strainer - BR640 with outside strainer - BR641 (Y)
- Installation in any position
- Optimized design for quick installation
- Maintenance simplified due to screwed cap without sealing
- Options: - Outside strainer with blow down valve (Pos. 46)

Operating limits

Fig. 45.640 / 45.641	PN40 - 1.0460		
Operating pressure PS (bar-g)	32	22	14,5
Operating temperature TS (°C)	250	385	450

allowable differential pressure ΔPMX (bar):	32
permissible pressure ratio (barg):	Back pressure / Inlet press. ≤ 0,8
min. operating pressure (barg)	0,7

Fig. 85.640 / 85.641	PN40 - 1.5415		
Operating pressure PS (bar-g)	35	32	28
Operating temperature TS (°C)	300	335	450

allowable differential pressure ΔPMX (bar):	32
permissible pressure ratio (barg):	Back pressure / Inlet press. ≤ 0,8
min. operating pressure (barg)	0,7

Fig. 55.640 / 55.641	PN40 - 1.4541	
Operating pressure PS (bar-g)	32	22
Operating temperature TS (°C)	350	400

allowable differential pressure ΔPMX (bar):	32
permissible pressure ratio (barg):	Back pressure / Inlet press. ≤ 0,8
min. operating pressure (barg)	0,7

Types of connection

Flanges1	PN40 acc. to DIN 2501
Screwed sockets2	R- and NPT-thread acc. to DIN EN 10226-1
Socket weld ends3	acc. to DIN EN 12760
Butt weld ends4	acc. to DIN EN 12627

Other types of connection on request.

For ANSI versions refer to data sheet CONA®TD-ANSI

Dimensions and Weights		Types of connection								
		Flanges			Screwed sockets Socket weld ends			Butt weld ends		
Nominal diameter	(mm) (inch)	15 1/2	20 3/4	25 1	15 1/2	20 3/4	25 1	15 1/2	20 3/4	25 1
L*	(mm)	150	150	160	95	95	95	250	250	250
H	(mm)	65	65	65	65	65	74	65	65	65
H1	(mm)	62	62	62	62	62	55	62	62	62
S	(mm)	40	40	40	40	40	40	40	40	40
S1	(mm)	24	24	24	24	24	13	24	24	24
HEX	(mm)	50	50	50	50	50	50	50	50	50
Weight approx.	(kg)	2,7	3,3	3,7	1,4	1,3	1,8	1,8	1,9	2

Standard-flange dimensions refer to page 7.

* Face-to-face acc. to data sheet resp. customer request

Parts

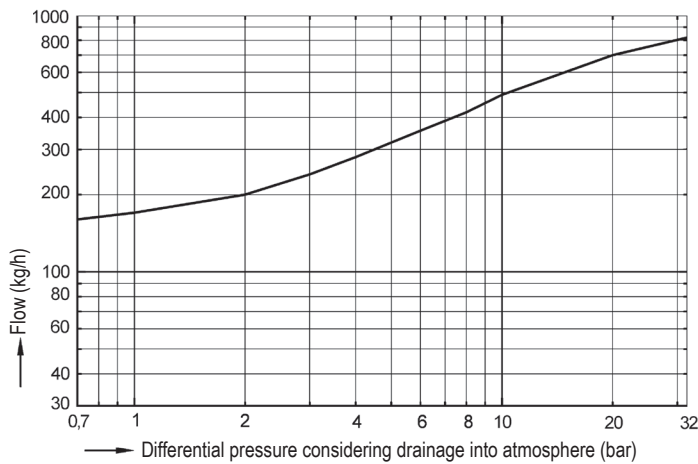
Pos.	Description	Fig. 45.640 / 45.641	Fig. 85.640 / 85.641	Fig. 55.640 / 55.641
1	Body	P250 GH, 1.0460	16Mo3, 1.5415	X6CrNiTi18-10, 1.4541
2	Strainer *	X5CrNi18-10, 1.4301		
6	Cap	P250 GH, 1.0460	16Mo3, 1.5415	X6CrNiTi18-10, 1.4541
7	Strainer screen *	X5CrNi18-10, 1.4301		
8	Strainer plug *	X8CrNiS18-9, 1.4305		
24	Controller *	X39CrMo17-1+QT, 1.4122+QT		
46	Blow down valve, cpl. *	X8CrNiS18-9, 1.4305		

* Spare part

Information / restriction of technical rules need to be observed!

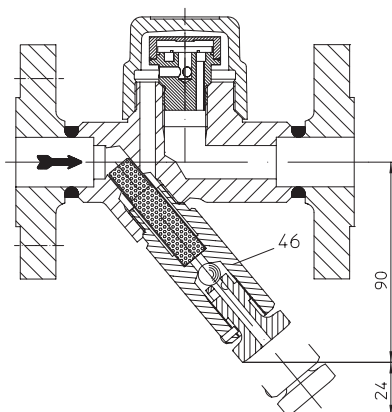
Operating instructions can be ordered by phone +49 (0)5207 / 994-0 or fax +49 (0)5207 / 994-158 or -159.

Capacity chart



The capacity chart shows the maximum flow of hot condensate for the standard controller
Flow rate of cold condensate at 20°C is about 1,5 times the volume of hot condensate

Options



Outside strainer with blow down valve

Thermodynamic steam trap (Stainless steel)

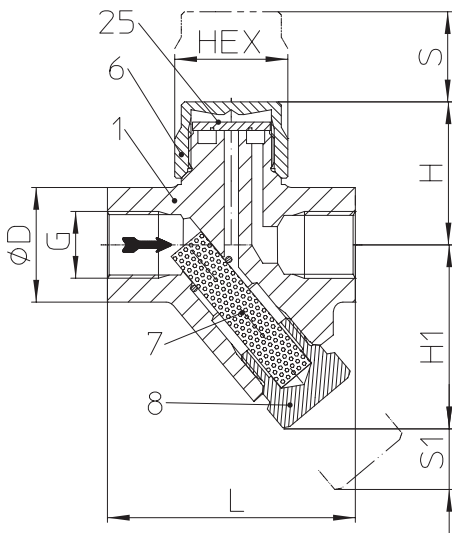


Fig. 641....2 with screwed sockets

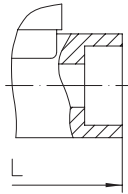


Fig. 641....3 with socket weld ends

- Thermodynamic steam trap of stainless steel for the condensate-discharge from all kinds of steam systems
- Intermittent mode of operation
- Robust and resistant to water-hammer
- Integrated non return protection
- with outside strainer
- Installation in any position
- Optimized design for quick installation
- Maintenance simplified due to screwed cap without sealing

Operating limits

Fig. 56.641	PN63 - 3/8"-3/4" 1"	= A743CA40 = 1.0460
Operating pressure PS (bar-g)	42	
Operating temperature TS (°C)	400	
allowable differential pressure ΔPMX (bar):	42	
permissible pressure ratio (barg):	Back pressure / Inlet press. ≤ 0,8	
min. operating pressure (barg)	1	

Types of connection

Screwed sockets2	R- and NPT-thread acc. to DIN EN 10226-1
Socket weld ends3 (DN15-20)	acc. to DIN EN 12760

Other types of connection on request.

Dimensions and Weights		Types of connection			
		Screwed sockets (3/8" - 1") Socket weld ends (DN15 - 20)			
Nominal diameter	(mm) (inch)	3/8	15 1/2	20 3/4	25 1
L*	(mm)	78	78	90	95
H	(mm)	47	47	50	59
H1	(mm)	56	56	56	61
S	(mm)	20	20	20	20
S1	(mm)	45	45	45	45
HEX	(mm)	32	32	32	41
Weight approx.	(kg)	0,8	0,8	0,8	0,9

Standard-flange dimensions refer to page 7.

* Face-to-face acc. to data sheet resp. customer request

Parts

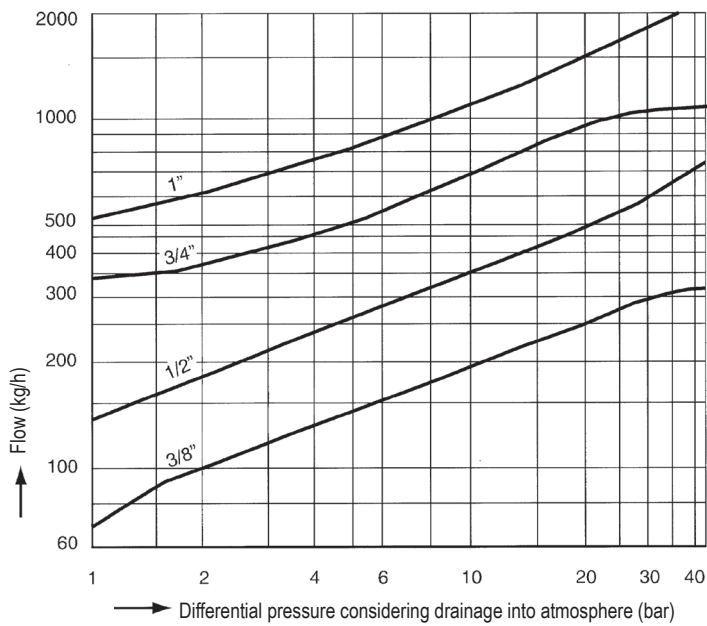
Pos.	Description	Fig. 56.641	
		Nominal diameter 3/8" - 3/4"	Nominal diameter 1"
1	Body	A743 CA40	X12Cr13, 1.4006
6	Cap	X8CrNiS18-9, 1.4305	
7	Strainer screen *	X5CrNi18-10, 1.4301	
8	Strainer plug *	X8CrNiS18-9, 1.4305	
25	Disc *	X39CrMo17-1+QT, 1.4122+QT	

* Spare part

Information / restriction of technical rules need to be observed!

Operating instructions can be ordered by phone +49 (0)5207 / 994-0 or fax +49 (0)5207 / 994-158 or -159.

Capacity chart



The capacity chart shows the maximum flow of hot condensate for the standard controller

Flow rate of cold condensate at 20°C is about 1,5 times the volume of hot condensate

Informations about pipe welding

Welding groove acc. to DIN 2559

The material used for ARI valves with butt weld ends are:	1.0460	P250GH acc. to DIN EN 10222-2
	1.5415	16Mo3 acc. to DIN EN 10028
	A743 CA40	acc. to ASTM A743/A743M-98a
	1.4006	X12Cr13 acc. to DIN EN 10250-4

Due to our experience, we recommend to apply an electric welding process.

Because of the different material compositions and wall thickness of the steam traps and the pipe gas welding shall not be applied. Quenching cracks and coarse grain structure may develop.

Steam traps with socket-weld ends shall only be welded by arc welding (welding process 111 acc. to DIN EN 24063).

If during the time of warranty others than the manufacturer or by the manufacturer authorized persons are interfering in the product and/or the setting, the right of claim for warranty will lapse!

Selection criteria:

- Steam pressure
- Back pressure
- Quantity of condensate
- Nominal diameter / pressure
- Type of connection
- Material
- Place of service or kind of steam consumer

Example for order data:

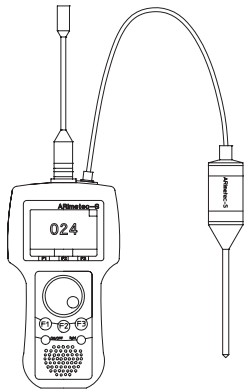
=> Thermodynamic steam trap CONA® TD,
 Fig. 640, PN 40, DN 15, 1.0460, with screwed sockets, Face-to-face dimension 150 mm

Dimensions in mm resp. inch
Weights in kg
1 bar $\hat{=}$ 10 ⁵ Pa $\hat{=}$ 0,1 MPa
Kvs in m ³ /h
1 bar $\hat{=}$ 14,5 psi
1 inch $\hat{=}$ 25,4 mm

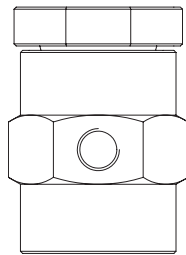
Standard-flange dimensions

Flanges according to DIN 2501

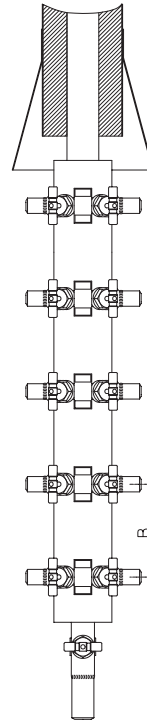
DN		(mm)	15	20	25
PN40	ØD	(mm)	95	105	115
PN40	ØK	(mm)	65	75	85
PN40	n x Ød	(mm)	4 x 14	4 x 14	4 x 14



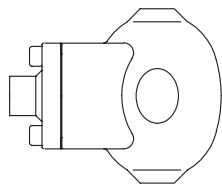
Multifunction tester **ARImetec®-S**



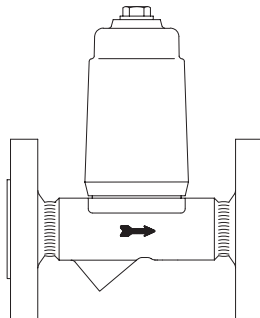
Vacuum breaker Fig. 655



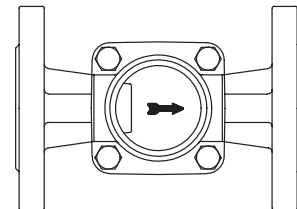
CONDIS®S with gland packing Fig. 671/672;
CONDIS®B with bellows seal, maintenance-free Fig. 675/676



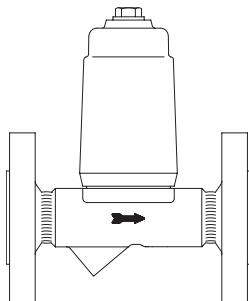
Automatic air vent for liquid systems
Fig. 656



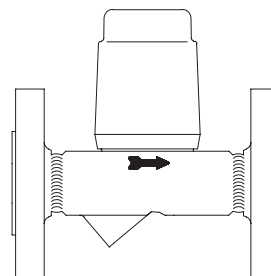
Condensate discharge temperature limiter
Fig. 645/647



Flow indicator
Fig. 660/661



Return temperature limiter Fig. 650



Liquid drainer Fig. 665

(Further informations about the accessories can be found in the appropriate data sheets.)