

Control valve in straightway form for combustible gases
DIN-DVGW type approval
DN 15 - 100

ARI-STEVI® 440-G / 441-G

for electric and pneumatic actuators

- DIN-DVGW type approval acc. to DIN 3391 and DIN EN 13611
- For control of fuel gas-supply systems

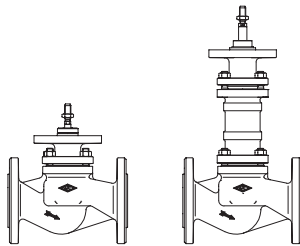

Page 2

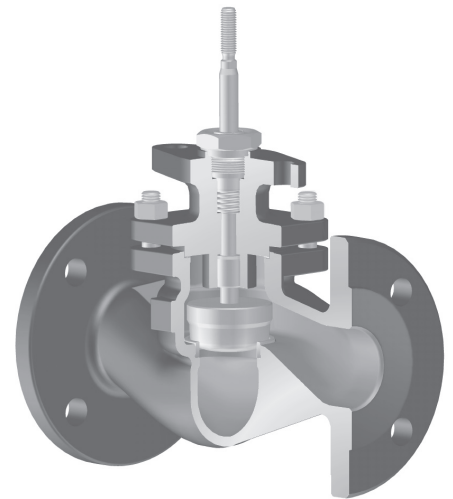
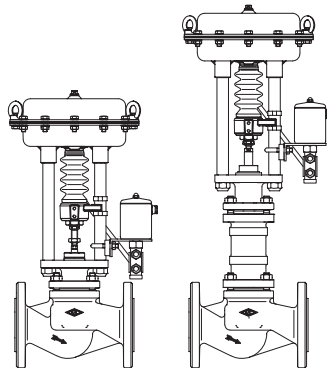

Fig. 440

Stell- und Schnellschlussventil
ARI-STEVI® 440 DP-G / 441 DP-G

- DIN-DVGW type approval acc. to DIN EN 161 and DIN 3394 Part 1
- For control of fuel gas-supply systems and emergency isolation facilities
- On power supply failure, the actuator closes the valve by spring force
- A strainer must be installed upstream of the valve
- Plug/seat isolation, body/bonnet and gasket sealing corresponds to the high demands of DIN EN 161 and DIN 3394 part 1 group A
- Closing time on power supply failure max. 1 second



Page 4

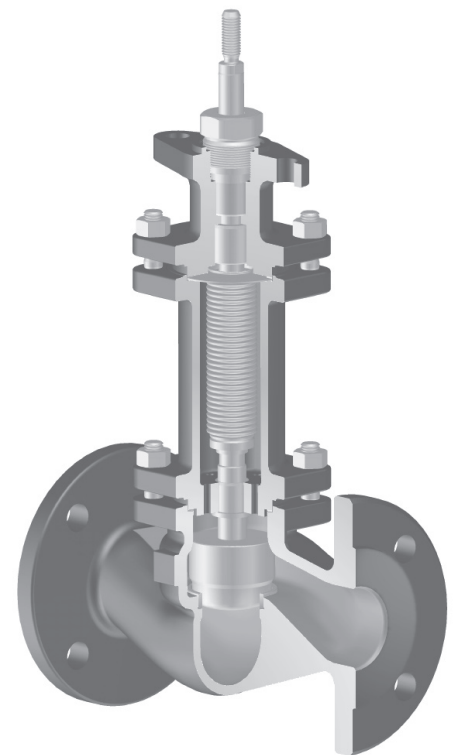

Fig. 441

Pneumatic actuator ARI-DP

- Actuator with rolling diaphragm
- Air supply pressure max. 6 bar
- Stem protection by bellow
- Maintenance-free O-ring sealing
- Assembly of additional devices acc. to DIN IEC 60534-6

Features:

- Compact design
- Precision guided stem
- Burnished stem
- Rangeability 50 : 1
- Spring loaded PTFE-V ring packing unit
- Two-ply bellows seal as standard
- Travel indicator

Control valve in straightway form for gas - DIN-DVGW type approval

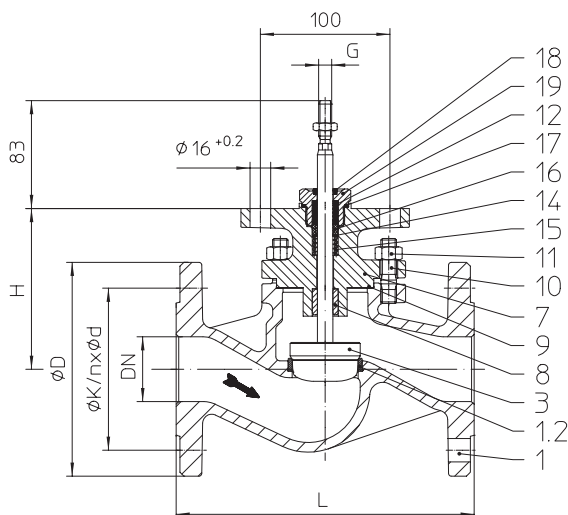

Fig. 440-G

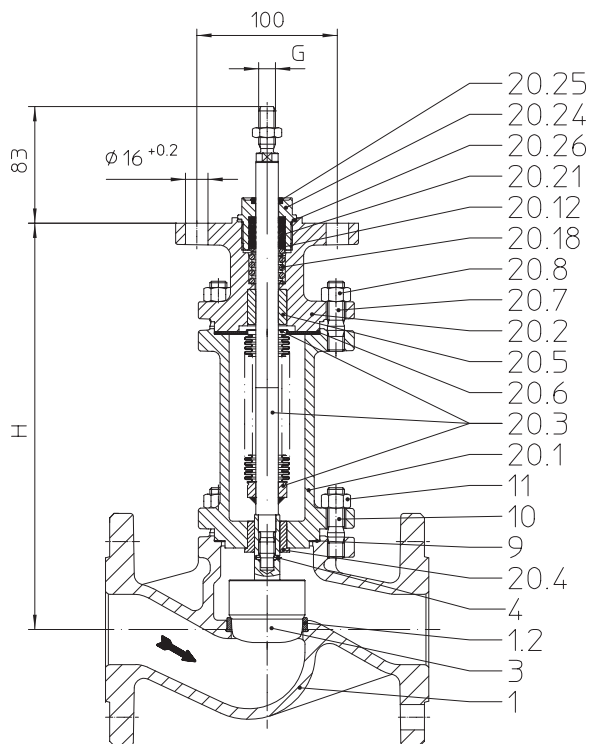

Fig. 441-G

Figure	Nominal pressure	Material	Nominal diameter
22.440-G / 22.441-G	PN16	EN-JS1049	DN15-100
23.440-G / 23.441-G	PN25	EN-JS1049	DN15-100
34.440-G / 34.441-G	PN25	1.0619+N	DN15-100
35.440-G / 35.441-G	PN40	1.0619+N	DN15-100
55.440-G / 55.441-G	PN40	1.4408	DN15-100
Stem sealing			
Fig. 440-G: • PTFE-V-ring unit			
Fig. 441-G: • Stainless steel-bellow with PTFE-V-ring unit			
Operative ambient temperature			
EN-JS1049: -10°C to +60°C			
1.0619+N: -20°C to +60°C			
1.4408: -20°C to +60°C			
(Please indicate when ordering)			
Mounting position			
• horizontal piping: vertical actuator			
• vertical piping: horizontal actuator (observe operating instruction)			
Plug design			
• Parabolic plug, metal seat			
• Parabolic plug with PTFE soft seat (max. 200°C)			
Guiding			
• Stem guiding			
Flow characteristic			
• Equal percentage or linear			
Rangeability			
• 50 : 1			
Flow direction			
• flow-to-open			
Shut off class (seat / plug leakage classes)			
• Metal seat - Leakage class IV acc. to DIN EN 1349 or IEC 60534-4			
• Soft seat Leakage - class VI acc. to DIN EN 1349 or IEC 60534-4			
Approvals			
• DIN-DVGW type approval according to DIN 3391 and DIN EN 13611 Registration No.: NG - 4396AP3149			
Operating ranges			
• Combustible gases acc. to DVGW page G260/1			
Actuator			
• pneumatic: DP32-34 (refer to data sheet Fig. 440/441)			
• electric: ARI-PREMIO 2,2 kN - 12 kN (refer to data sheet Fig. 440/441) AUMA SAR 07.1 - 10.1			
The electrical equipment must be according to DIN 3391.			
Corrosion protection (alternative)			
• only for storage and transport			
• customized painting			
Closing pressures refer to page 3.			
Technical data for actuator refer to data sheet.			

Dimensions and weights

DN			15	25	40	50	80	100	
L		(mm)	130	160	200	230	310	350	
Fig. 440-G	H	(mm)	103	111	118	124	152	171	
	EN-JS1049	PN16 / PN25	(kg)	4	5,5	9,1	11,8	22,9	36,9
	1.0619+N / 1.4408	PN25 / PN40	(kg)	4,3	6,1	10	13	26	38,7
Fig. 441-G	H	(mm)	288	296	287	289	385	401	
	EN-JS1049	PN16 / PN25	(kg)	9	12,6	20,7	23	38,3	53
	1.0619+N / 1.4408	PN25 / PN40	(kg)	10	14	23	25,5	42,5	59

Standard-flange dimensions refer to page 7

Heights and weights incl. actuator refer to corresponding data sheet.

Face-to-face dimension FTF series 1 according to DIN EN 558-1

Closing pressures and thrust

DN			15	25	40	50	80	100	
Seat-ø		(mm)	21	27	41	51	81	101	
Standard Kvs-values			4	10	25	40	100	160	
Reduced Kvs-values			2,5	6,3	16	25	63	100	
Travel		(mm)	20				30		
Max. permissible closing pressure		(bar)				16			
Required thrust at the stem			(kN)	1,3	1,5	2,8	4,1	9,4	14,2
Max. permissible thrust to the stem	Fig. 440	(kN)	12				29		
	Fig. 441	(kN)	18						

Parts

Pos.	Description	Fig. 22.440 / 22.441 Fig. 23.440 / 23.441	Fig. 34.440 / Fig. 34.441 Fig. 35.440 / Fig. 35.441	Fig. 55.440 / Fig. 55.441
1	Body	EN-GJS-400-18U-LT, EN-JS1049	GP240GH+N, 1.0619+N	GX5CrNiMo19-11-2, 1.4408
1.2	Seat ring	X20Cr13+QT, 1.4021+QT	X20Cr13+QT, 1.4021+QT > DN50: G19 9 Nb Si, 1.4551	--
3	Plug *	X20Cr13+QT, 1.4021+QT		X6CrNiMoTi17-12-2, 1.4571
4	Straight pin *	X10CrNi18-8, 1.4310		A4 - 70
7	Mounting bonnet	EN-GJS-400-18U-LT, EN-JS1049	GP240GH+N, 1.0619+N	GX5CrNiMo19-11-2, 1.4408
8	Guide bushing	X20Cr13+QT, 1.4021+QT (hardened)		X6CrNiMoTi17-12-2, 1.4571
9	Gasket *	Pure graphite (CrNi laminated with graphite)		
10	Studs	25CrMo4, 1.7218		A4 - 70
11	Hexagon nuts	C35E, 1.1181		A4
12	V-ring unit *	PTFE		
14	Washer *	X5CrNi18-10, 1.4301		
15	Spring *	X10CrNi18-8, 1.4310		
16	Bushing *	PTFE (reinforced)		
17	Sealing ring *	Cu / Soft iron		
18	Scraper *	PTFE (reinforced)		
19	Screw joint *	X8CrNiS18-9, 1.4305		
20.1	Bellows housing	EN-GJS-400-18U-LT, EN-JS1049	GP240GH+N, 1.0619+N	GX5CrNiMo19-11-2, 1.4408
20.2	Mounting bonnet	EN-GJS-400-18U-LT, EN-JS1049	GP240GH+N, 1.0619+N	GX5CrNiMo19-11-2, 1.4408
20.3	Stem- / Bellows unit *	X20Cr13+QT, 1.4021+QT / X6CrNiTi18-10, 1.4541		X6CrNiMoTi17-12-2, 1.4571
20.4	Guide bushing	X20Cr13+QT, 1.4021+QT (hardened)		X6CrNiMoTi17-12-2, 1.4571
20.5	Guide bushing	X20Cr13+QT, 1.4021+QT (hardened)		X6CrNiMoTi17-12-2, 1.4571
20.6	Gasket *	Pure graphite (CrNi laminated with graphite)		
20.7	Studs	25CrMo4, 1.7218		A4 - 70
20.8	Hexagon nuts	C35E, 1.1181		A4
20.12	Washer *	X5CrNi18-10, 1.4301		
20.18	Spring	X10CrNi18-8, 1.4310		
20.21	V-ring unit *	PTFE		
20.24	Screw joint *	X8CrNiS18-9, 1.4305		
20.25	Scraper *	PTFE (reinforced)		
20.26	Sealing ring *	Cu / Soft iron		

* Spare parts

Information / restriction of technical rules need to be observed!

A production allowance acc. to TRB 801 No. 45 exists

The engineer, designing a system or a plant, is responsible for the selection of the correct valve.

Pneumatic control and quickclosing valve in straightway form for gas - DIN-DVGW type approval

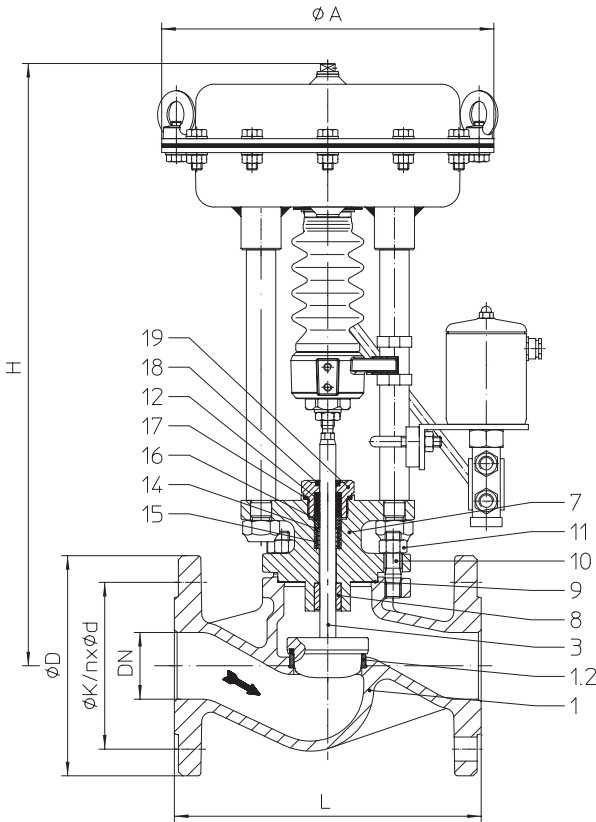

Fig. 440-G

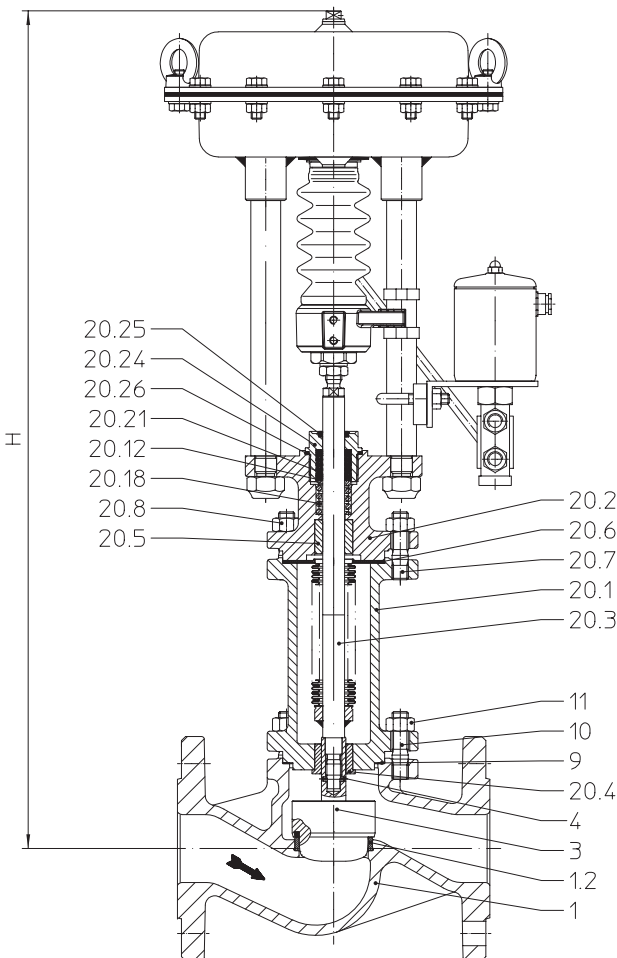

Fig. 441-G

Figure	Nominal pressure	Material	Nominal diameter
23.440 DP-G / 23.441 DP-G	PN25	EN-JS1049	DN15-100
34.440 DP-G / 34.441 DP-G	PN25	1.0619+N	DN15-100
35.440 DP-G / 35.441 DP-G	PN40	1.0619+N	DN15-100
55.440 DP-G / 55.441 DP-G	PN40	1.4408	DN15-100
Stem sealing			
Fig. 440 DP-G:	• PTFE-V-ring unit		
Fig. 441 DP-G:	• Stainless steel-bellow with PTFE-V-ring unit		
Operative ambient temperature			
EN-JS1049:	-10°C to +60°C		
1.0619+N:	-20°C to +60°C		
1.4408:	-20°C to +60°C		
(Please indicate when ordering)			
Mounting position			
• horizontal piping: vertical actuator			
• vertical piping: horizontal actuator (observe operating instruction)			
Plug design			
• Parabolic plug with PTFE soft seat (max. 200°C)			
Guiding			
• Stem guiding			
Flow characteristic			
• Equal percentage or linear			
Rangeability			
• 50 : 1			
Closing time			
• max. 1 second			
Flow direction			
• flow-to-open			
Shut off class and stem sealing			
• in correspondence to the high demands of DIN EN 161 and DIN 3394 part 1 class A			
Approvals			
• DIN-DVGW type approval according to DIN EN 161 and DIN 3394 part 1 class A Registration No.: STEVI® 440 DP-G: CE - 0085 BM 0068 STEVI® 441 DP-G: CE - 0085 BM 0069			
Operating ranges			
• Combustible gases acc. to DVGW page G260/1			
Control			
• 3/2 way-solenoid valve actuated directly (Technical data on page 7)			
Corrosion protection (alternative)			
• only for storage and transport			
• customized painting			
Strainer			
• upstream, mesh width 0,25 mm (Dimensions open Page 6)			
Closing pressures refer to page 6.			
Technical data for actuator refer to data sheet.			

A strainer must be installed upstream of the valve (mesh width 0,25 mm) !
(Further information refer to page 6)

Dimensions and weights

DN			15	25	40	50	80	100
L	(mm)		130	160	200	230	310	350
Ø A	(mm)		250					
Fig. 440 DP32 - G	H	(mm)	442	450	457	463	580	499
	PN25	(kg)	13	14,5	18,1	20,8	31,9	46
	PN40	(kg)	13,4	15,5	19,8	22,5	35,9	49
Fig. 441 DP32 - G	H	(mm)	627	635	626	628	713	729
	PN25	(kg)	17	18	23	25	39,5	55
	PN40	(kg)	19	23	32	34,5	51,5	68
Ø A	(mm)		300					
Fig. 440 DP33 - G	H	(mm)	497	505	512	518	546	565
	PN25	(kg)	19	20,5	24,1	26,8	37,9	52
	PN40	(kg)	19,4	21,5	25,8	28,5	41,9	55
Fig. 441 DP33 - G	H	(mm)	682	690	681	683	779	795
	PN25	(kg)	23	24	29	31,5	45,5	61
	PN40	(kg)	25	29	38	40,5	57,5	74
Ø A	(mm)		405					
Fig. 440 DP34 - G	H	(mm)					681	680
	PN25	(kg)					67,9	82
	PN40	(kg)					71,9	85
Fig. 441 DP34 - G	H	(mm)					914	930
	PN25	(kg)					75,5	91
	PN40	(kg)					87,5	104

Standard-flange dimensions refer to page 7

Face-to-face dimension FTF series 1 according to DIN EN 558-1

Parts

Pos.	Description	Fig. 23.440 / 23.441	Fig. 34.440 / Fig. 34.441 Fig. 35.440 / Fig. 35.441	Fig. 55.440 / Fig. 55.441
1	Body	EN-GJS-400-18U-LT, EN-JS1049	GP240GH+N, 1.0619+N	GX5CrNiMo19-11-2, 1.4408
1.2	Seat ring	X20Cr13+QT, 1.4021+QT	X20Cr13+QT, 1.4021+QT > DN50: G19 9 Nb Si, 1.4551	--
3	Plug *	X20Cr13+QT, 1.4021+QT		X6CrNiMoTi17-12-2, 1.4571
4	Straight pin *	X10CrNi18-8, 1.4310		A4 - 70
7	Mounting bonnet	EN-GJS-400-18U-LT, EN-JS1049	GP240GH+N, 1.0619+N	GX5CrNiMo19-11-2, 1.4408
8	Guide bushing	X20Cr13+QT, 1.4021+QT (hardened)		X6CrNiMoTi17-12-2, 1.4571
9	Gasket *	Pure graphite (CrNi laminated with graphite)		
10	Studs	25CrMo4, 1.7218		A4 - 70
11	Hexagon nuts	C35E, 1.1181		A4
12	V-ring unit *	PTFE		
14	Washer *	X5CrNi18-10, 1.4301		
15	Spring *	X10CrNi18-8, 1.4310		
16	Bushing *	PTFE (reinforced)		
17	Sealing ring *	Cu / Soft iron		
18	Scraper *	PTFE (reinforced)		
19	Screw joint *	X8CrNiS18-9, 1.4305		
20.1	Bellows housing	EN-GJS-400-18U-LT, EN-JS1049	GP240GH+N, 1.0619+N	GX5CrNiMo19-11-2, 1.4408
20.2	Mounting bonnet	EN-GJS-400-18U-LT, EN-JS1049	GP240GH+N, 1.0619+N	GX5CrNiMo19-11-2, 1.4408
20.3	Stem- / Bellows unit *	X20Cr13+QT, 1.4021+QT / X6CrNiTi18-10, 1.4541		X6CrNiMoTi17-12-2, 1.4571
20.4	Guide bushing	X20Cr13+QT, 1.4021+QT (hardened)		X6CrNiMoTi17-12-2, 1.4571
20.5	Guide bushing	X20Cr13+QT, 1.4021+QT (hardened)		X6CrNiMoTi17-12-2, 1.4571
20.6	Gasket *	Pure graphite (CrNi laminated with graphite)		
20.7	Studs	25CrMo4, 1.7218		A4 - 70
20.8	Hexagon nuts	C35E, 1.1181		A4
20.12	Washer *	X5CrNi18-10, 1.4301		
20.18	Spring	X10CrNi18-8, 1.4310		
20.21	V-ring unit *	PTFE		
20.24	Screw joint *	X8CrNiS18-9, 1.4305		
20.25	Scraper *	PTFE (reinforced)		
20.26	Sealing ring *	Cu / Soft iron		

* Spare parts

Information / restriction of technical rules need to be observed!

A production allowance acc. to TRB 801 No. 45 exists

The engineer, designing a system or a plant, is responsible for the selection of the correct valve.

max. permissible closing pressures on flow-to-open P2 = 0

Spring closes									
DN	15	25	40	50	80	100			
Seat- ϕ (mm)	21	27	41	51	81	101			
Standard Kvs-values	4	10	25	40	100	160			
Reduced Kvs-values	2,5	6,3	16	25	63	100			
Travel (mm)	20				30				
Actuator DP32 Control valve 2401103.0801 2401103.0807	Spring range (bar)	0,4 - 1,2	1,4	15,4	8,6	2,9	1,5		
		0,8 - 2,4	2,7	40	24,9	10	6,2		
Actuator DP33 Control valve 2401550.1300 2401550.1301	Spring range (bar)	0,4 - 1,2	1,4	32,1 c)	18,8 c)	7,4 c)	4,4 c)	1,1	0,5
		0,8 - 2,4	2,7	40	40	18,9	12	4,1	2,5
		1,5 - 3,0	3,3					8,6	5,4
		1,7 - 2,7	3,1			40	28,9		
		2,3 - 3,7	4,2			40	40		
Actuator DP34 Control valve 2402450.1300 2402450.1301	Spring range (bar)	0,4 - 1,2	1,4					13,1	8,3
		0,8 - 2,4	2,7					4,2 b)	2,5 b)
		2,1 - 3,0	3,3					10,3 c)	6,4 c)
		2,4 - 3,6	4,2					29,9	19,1
Air supply pressure max. to actuator			a) 2,5 bar	b) 3,5 bar	c) 4,5 bar				

Strainer

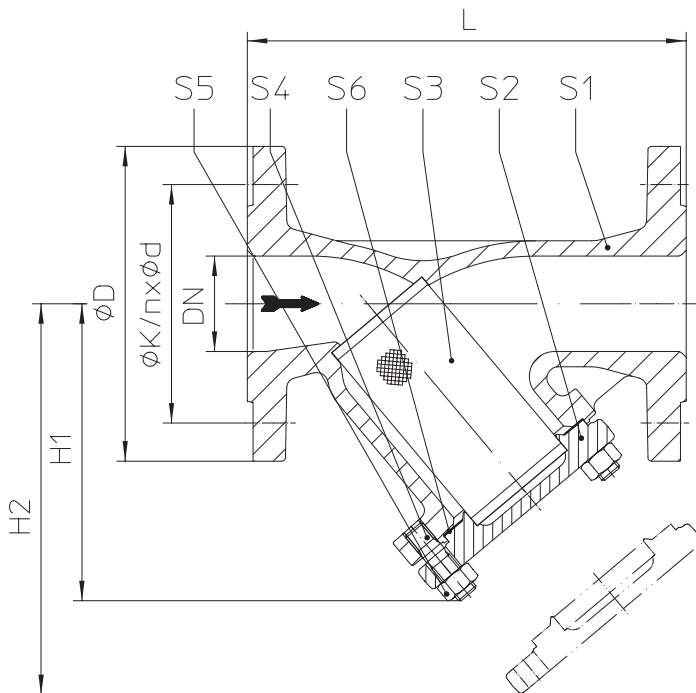

Dimensions

DN	H1	H2
	(mm)	(mm)
15	90	135
25	115	180
40	150	235
50	160	250
80	215	330
100	235	365

Standard-flange dimensions refer to page 7

Technical data and versions for ARI-Strainer refer to corresponding data sheet.

Parts

Pos.	Description	Fig. 23.050	Fig. 35.050	Fig. 55.059
S1	Body	EN-GJS-400-18U-LT, EN-JS1049	GP240GH+N, 1.0619+N	GX5CrNiMo19-11-2, 1.4408
S2	Cover	EN-GJS-400-18U-LT, EN-JS1049	P250GH, 1.0460	X6CrNiMoTi17-12-2, 1.4571
S3	Screen *	X5CrNi18-10, 1.4301		X6CrNiMoTi17-12-2, 1.4571
S4	Stud	25CrMo4, 1.7218	25CrMo4, 1.7218 / A4-70	A4-70
S5	Hexagon nut	C35E, 1.1181	C35E, 1.1181 / A4-70	A4-70
S6	Gasket *	Pure graphite (CrNi laminated with graphite)		

* Spare parts

Standard-flange dimensions

Flanges acc. to DIN EN1092-1 / -2 (Flangeholes / -thickness tolerances acc. to DIN 2533 / 2544 / 2545)

DN			15	25	40	50	80	100
PN16	Ø D	(mm)	95	115	150	165	200	220
	Ø K	(mm)	65	85	110	125	160	180
	n x Ø d1	(mm)	4 x 14	4 x 14	4 x 18	4 x 18	8 x 18	8 x 18
PN25	Ø D	(mm)	95	115	150	165	200	235
	Ø K	(mm)	65	85	110	125	160	190
	n x Ø d1	(mm)	4 x 14	4 x 14	4 x 18	4 x 18	8 x 18	8 x 22
PN40	Ø D	(mm)	95	115	150	165	200	235
	Ø K	(mm)	65	85	110	125	160	190
	n x Ø d1	(mm)	4 x 14	4 x 14	4 x 18	4 x 18	8 x 18	8 x 22

Control valve

Type	2401103.0801 / 0807		2401550.1300 / 1301		2402450.1300 / 1301	
Nominal diameter	DN 5		DN 8		DN 12	
Thread connection	G 1/4		G 1/4		G 3/8	
Magnet coil No.	0801	0807	1300	1301	1300	1301
Standard voltages	24V DC	230V 50Hz 24V 50Hz	24V DC	230V 50Hz 24V 50Hz	24V DC	230V 50Hz 24V 50Hz
Power consumption	16 W	18 W	20 W	24 W	20 W	24 W
Duty cycle	ED 100%					
Electric connection	Design acc. to VDE 0508		Screwed cable gland Pg 13,5			
Enclosure	acc. to DIN 40050 IP65					
Design acc. to VDE 0508			Explosion proof version and other voltages on request.			

Accessories

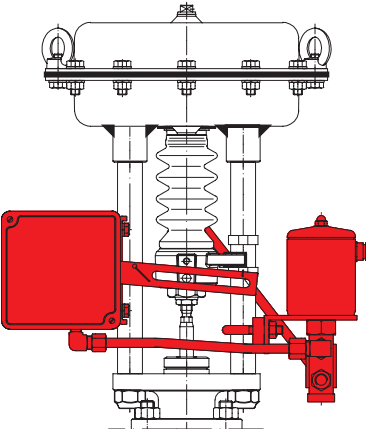

Pneumatic or electro pneumatic positioner

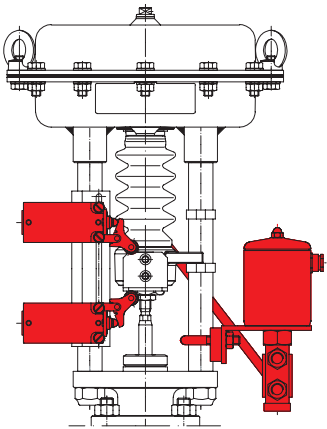

Electric limit switch

- Electric limit switch
- Throttle valve for prolonged opening time
- Air set

Please indicate when ordering

- | | |
|--------------------|--------------------------------|
| - Figure-No. | - Kvs-value |
| - Nominal diameter | - Flow characteristic |
| - Nominal pressure | - Stem sealing |
| - Body material | - Actuator |
| - Plug design | - Special design / accessories |

Example:

Figure 35.440-G; Nominal diameter DN100; Nominal pressure PN40; Body material 1.0619+N; Parabolic plug; Kvs 160; GLP; Stem sealing PTFE-V-ring unit; Actuator DP 33; Spring closes; Spring range 1,4-2,9 bar.

 Dimensions in mm
 Weights in kg
 Pressures in barg (gauge)
 1 bar $\hat{=}$ 10⁵ Pa $\hat{=}$ 0,1 MPa
 Kvs in m³/h

Stem sealing

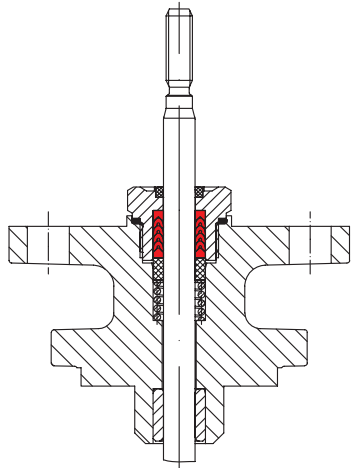

Spring loaded PTFE-V ring packing unit

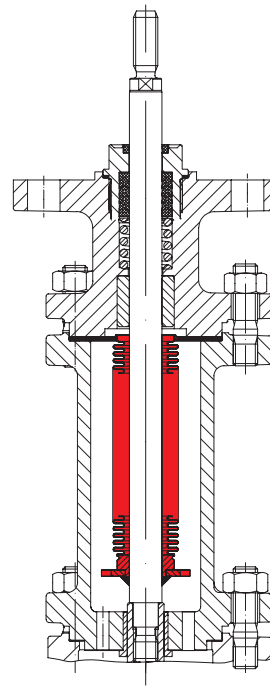

Bellows seal with V-ring unit

Body design

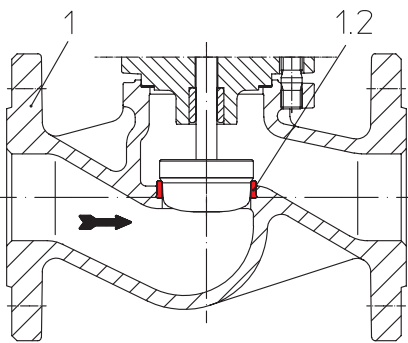

Body with pressed seat ring
(EN-JS1049)

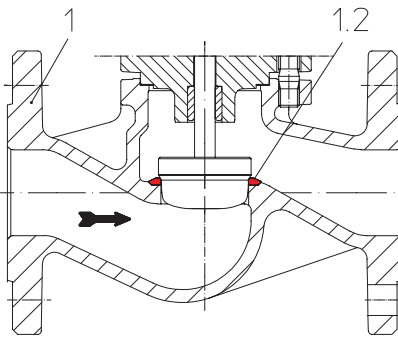

Body with welded seat
(1.0619+N)

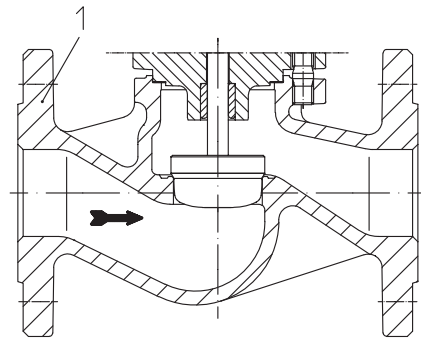

Body with machined seat (1.4408)

Plug design

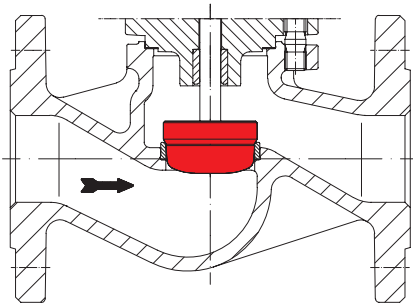

Parabolic plug (Fig. 440-G / 441-G)

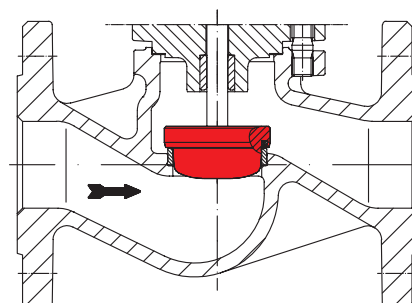

Parabolic plug with PTFE soft seat (Fig. 440 DP-G / 441 DP-G)