

Control valve in 3-way-form (3-way mixing valve)

DN 300

ARI-STEVI® 423

Electric actuator CS

- Enclosure IP 65
- 2 torque switches
- Handwheel
- Additional devices available, e.g. potentiometer

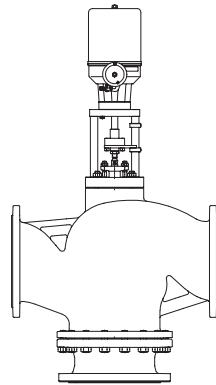

Page 2

ARI-STEVI® 423

Electric actuator AUMA SAR

- Electric multiturn actuator, capable of high closing pressures
- Enclosure IP 67
- 2 torque switches
- 2 travel switches
- Handwheel
- Overheating protection for motor as standard
- Additional devices available, e.g. potentiometer
- Explosion proof version available

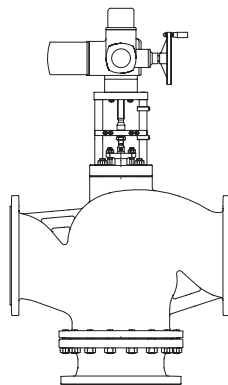

Page 6

ARI-STEVI® 423

Pneumatic actuator ARI-DP

- Reversible pneumatic actuator
- Actuator with rolling diaphragm
- Air supply pressure max. 6 bar
- Stem protection by bellow
- Maintenance-free O-ring sealing
- Assembly of additional devices acc. to DIN IEC 60534-6

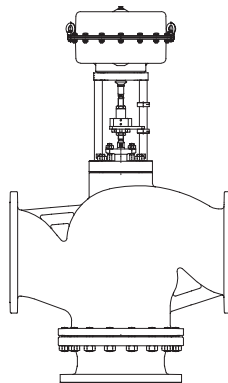

Page 10

Features:

- Precision guided stem
- Burnished stem
- Replaceable seat and plug
- 1 Screwed seat ring
- Reducible kvs-values
- Rangeability 30 : 1
- Post guided plug
- Travel indicator

Control valve in 3-way-form with electric actuator CS

Figure	Nominal pressure	Material	Nominal diameter
22.423	PN16	EN-JS1049	DN300
Stem sealing			
Fig. 423: <ul style="list-style-type: none"> • PTFE-packing -10°C to +250°C • Pure graphite-packing -10°C to +450°C • EPDM-Shut off class 0°C to +130°C 			
Plug design			
• V-port plug			
Guiding			
• Port guiding			
Flow characteristic			
• linear			
Rangeability			
• 30 : 1			
Shut off class (seat / plug leakage classes)			
• Metal seat - Leakage class IV acc. to DIN EN 1349 or IEC 60534-4			
Closing pressures refer to page 4.			
Technical data for actuator refer to data sheet.			

Selection of possible applications

Heating-, Ventilation- and Air-Conditioning- Systems, etc.
 (other applications on request)

Selection of possible flow media

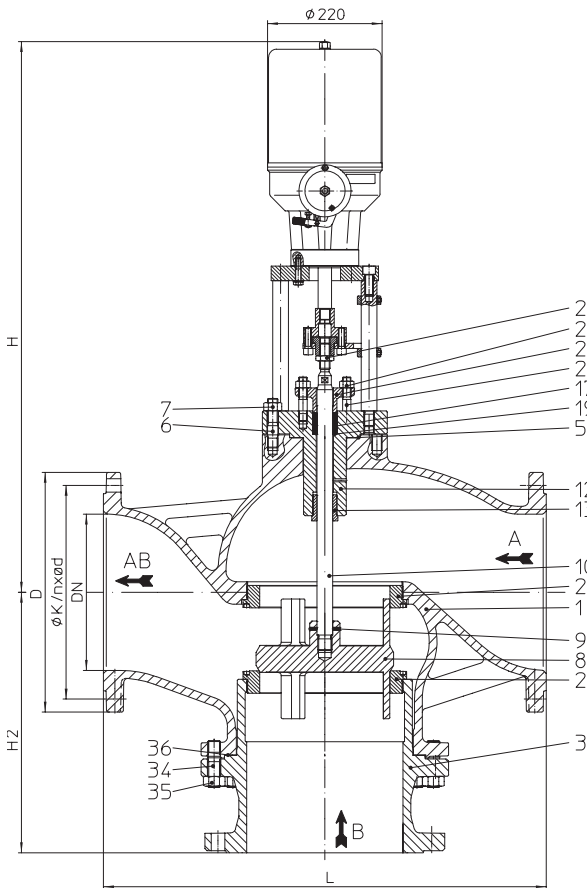
Water, Water with cold-protection
 (other flow media on request)

Fig. 423

Dimensions and weights

DN			300
L		(mm)	850
H2		(mm)	500
Fig. 423	H	(mm)	1057
	CS 27	PN16	(kg)
Standard-flange dimensions refer to page 15.			

Face-to-face dimension FTF series 1 according to DIN EN 558-1

Parts

Pos.	Description	Fig. 22.423
1	Body	EN-GJS-400-18U-LT, EN-JS1049
2	Seat ring *	X20Cr13+QT, 1.4021+QT
3	Bottom flange	EN-GJS-400-18U-LT, EN-JS1049
5	Gasket *	Pure graphite (CrNi laminated with graphite)
6	Studs	25CrMo4, 1.7218
7	Hexagon nut	C35E, 1.1181
8	Plug *	X20Cr13+QT, 1.4021+QT
9	Straight pin *	X10CrNi18-8, 1.4310
10	Stem *	X20Cr13+QT, 1.4021+QT
12	Stuffing box housing	P250 GH, 1.0460
13	Guide bushing	X20Cr13+QT, 1.4021+QT (hardened)
17	Packing ring *	PTFE or Pure graphite
19	Washer *	X5CrNi18-10, 1.4301
20	Packing box flange	EN-GJS-400-18U-LT, EN-JS1049
21	Studs	25CrMo4, 1.7218
22	Hexagon nut	C35E, 1.1181
26	Hexagon nut	17H-A4G
34	Studs	25CrMo4, 1.7218
35	Hexagon nut	C35E, 1.1181
36	Gasket *	Pure graphite (CrNi laminated with graphite)
* Spare parts		

Information / restriction of technical rules need to be observed!

A production allowance acc. to TRB 801 No. 45 exists

The engineer, designing a system or a plant, is responsible for the selection of the correct valve.

max. permissible closing pressures for both seat positions on flow-to-open P2 = 0 (Observe regulations, refer to page 15.)

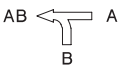
Mixing function	DN		300		
		Standard Kvs-values	Seat-Ø A/B (mm)		250
Kvs-value				1500	
Travel (mm)				75	
Reduced Kvs-values		Seat-Ø A/B (mm)	250		
		Kvs-value	1000		
		Travel (mm)	65		
Actuator ¹⁾ CS 27 24 kN	Closing pressure (bar)		4,3	4,3	
	Operating time ²⁾ (s) (Op. speed 0,84 mm/s)		77	89	

¹⁾ Motor voltage: 230V 50Hz 1Ø
Other voltages: 24V 50Hz 1Ø; 400V 50Hz 3~
Technical data for actuator refer to data sheet CS.

²⁾ Indicated operating times with 50Hz.

Control valve in 3-way-form with electric actuator AUMA

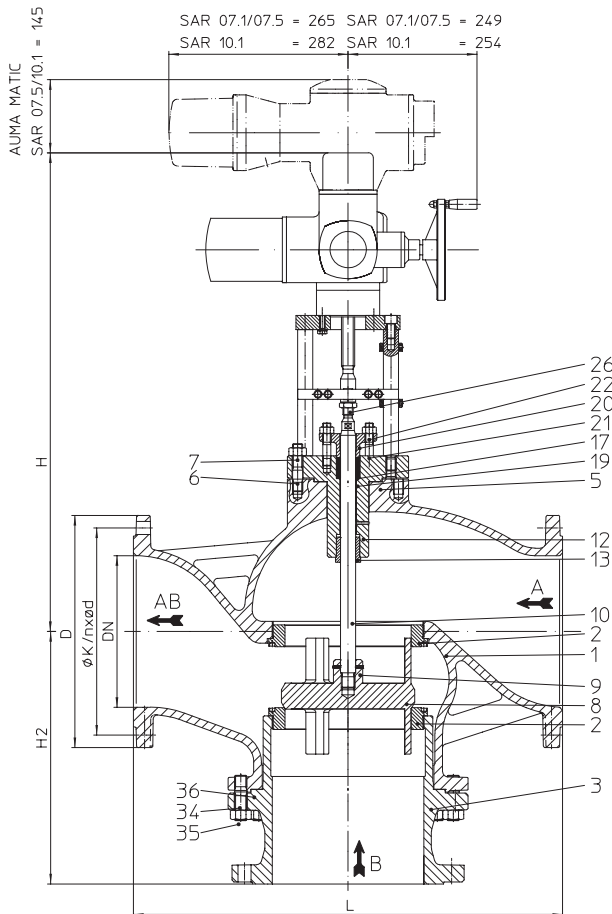

Figure	Nominal pressure	Material	Nominal diameter
22.423	PN16	EN-JS1049	DN300
Stem sealing			
Fig. 423: <ul style="list-style-type: none"> • PTFE-packing -10°C to +250°C • Pure graphite-packing -10°C to +450°C • EPDM-Shut off class 0°C to +130°C 			
Plug design			
• V-port plug			
Guiding			
• Port guiding			
Flow characteristic			
• linear			
Rangeability			
• 30 : 1			
Shut off class (seat / plug leakage classes)			
• Metal seat - Leakage class IV acc. to DIN EN 1349 or IEC 60534-4			
Closing pressures refer to page 8.			
Technical data for actuator refer to data sheet.			

Selection of possible applications

Heating-, Ventilation- and Air-Conditioning- Systems, etc.
(other applications on request)

Selection of possible flow media

Water, Water with cold-protection
(other flow media on request)

Fig. 423

Dimensions and weights

DN			300	
L		(mm)	850	
H2		(mm)	500	
Fig. 423	H	(mm)	936	
	AUMA SAR 07.1	PN16	(kg)	approx. 518
	H	(mm)	936	
	AUMA SAR 07.5	PN16	(kg)	approx. 518
	H	(mm)	951	
	AUMA SAR 10.1	PN16	(kg)	approx. 522
Standard-flange dimensions refer to page 15.			(For version with AUMA SAR Ex other heights.)	

Face-to-face dimension FTF series 1 according to DIN EN 558-1

Parts

Pos.	Description	Fig. 22.423
1	Body	EN-GJS-400-18U-LT, EN-JS1049
2	Seat ring *	X20Cr13+QT, 1.4021+QT
3	Bottom flange	EN-GJS-400-18U-LT, EN-JS1049
5	Gasket *	Pure graphite (CrNi laminated with graphite)
6	Studs	25CrMo4, 1.7218
7	Hexagon nut	C35E, 1.1181
8	Plug *	X20Cr13+QT, 1.4021+QT
9	Straight pin *	X10CrNi18-8, 1.4310
10	Stem *	X20Cr13+QT, 1.4021+QT
12	Stuffing box housing	P250 GH, 1.0460
13	Guide bushing	X20Cr13+QT, 1.4021+QT (hardened)
17	Packing ring *	PTFE or Pure graphite
19	Washer *	X5CrNi18-10, 1.4301
20	Packing box flange	EN-GJS-400-18U-LT, EN-JS1049
21	Studs	25CrMo4, 1.7218
22	Hexagon nut	C35E, 1.1181
26	Hexagon nut	17H-A4G
34	Studs	25CrMo4, 1.7218
35	Hexagon nut	C35E, 1.1181
36	Gasket *	Pure graphite (CrNi laminated with graphite)
* Spare parts		

Information / restriction of technical rules need to be observed!

A production allowance acc. to TRB 801 No. 45 exists

The engineer, designing a system or a plant, is responsible for the selection of the correct valve.

max. permissible closing pressures for both seat positions on flow-to-open P2 = 0 (Observe regulations, refer to page 15.)

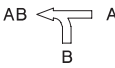
Mixing function	DN		300		
		Standard Kvs-values	Seat-Ø A/B (mm)		250
Kvs-value				1500	
Travel (mm)				75	
Reduced Kvs-values		Seat-Ø A/B (mm)	250		
		Kvs-value	1000		
		Travel (mm)	65		
Actuator ¹⁾ AUMA SAR 07.1 Output drive Form A TR 20 x 4	Closing pressure (bar)	shut off	2,8	2,8	
		controlling	1,6	1,6	
	Torque (Nm)		30		
	Operating time ²⁾ (s)		122	141	
	Output drive (rpm)		8	8	
Actuator ¹⁾ AUMA SAR 07.5 Output drive Form A TR 26 x 5	Closing pressure (bar)	shut off	4,1	4,1	
		controlling	2,2	2,2	
	Torque (Nm)		60		
	Operating time ²⁾ (s)		71	82	
	Output drive (rpm)		11	11	
Actuator ¹⁾ AUMA SAR 10.1 Output drive Form A TR 26 x 5	Closing pressure (bar)	shut off	8,8	8,8	
		controlling	4,5	4,5	
	Torque (Nm)		120		
	Operating time ²⁾ (s)		71	82	
	Output drive (rpm)		11	11	

¹⁾ Motor voltage: 400V 50Hz 3~
 (Other voltages on request)
 Technical data for actuator refer to price list.

²⁾ Indicated operating times with 50Hz.

Control valve in 3-way-form with pneumatic actuator DP

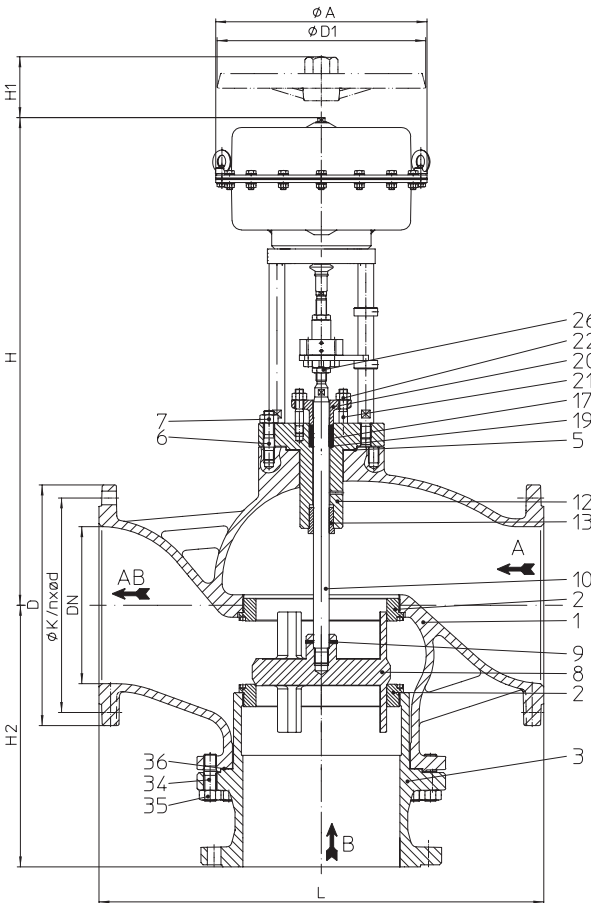

Fig. 423

Figure	Nominal pressure	Material	Nominal diameter
22.423	PN16	EN-JS1049	DN300
Stem sealing			
Fig. 423: <ul style="list-style-type: none"> • PTFE-packing -10°C to +250°C • Pure graphite-packing -10°C to +450°C • EPDM-Shut off class 0°C to +130°C 			
Plug design			
• V-port plug			
Guiding			
• Port guiding			
Flow characteristic			
• linear			
Rangeability			
• 30 : 1			
Shut off class (seat / plug leakage classes)			
• Metal seat - Leakage class IV acc. to DIN EN 1349 or IEC 60534-4			
Closing pressures refer to page 12.			
Technical data for actuator refer to data sheet.			

Selection of possible applications

Heating-, Ventilation- and Air-Conditioning- Systems, etc.
(other applications on request)

Selection of possible flow media

Water, Water with cold-protection
(other flow media on request)

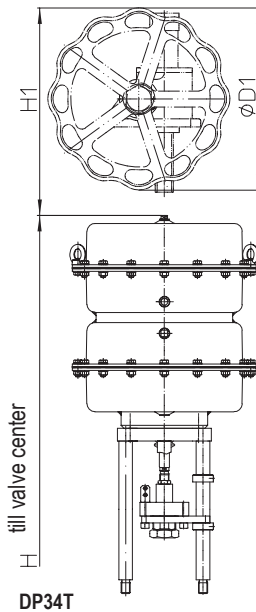

DP34T

Failure position dependent on valve duty.

Retracted stem on air failure:

- with a mixing valve port A -> AB is closed

Extended stem on air failure:

- with a mixing valve port B -> AB is closed

Top mounted handwheel

Actuator		DP34	DP34T
Ø D1	(mm)	397	400
H1	(mm)	458	608
Weight	(kg)	17	41
Technical data for actuator refer to data sheet DP32-34Tri.			

Dimensions and weights

DN			300
L		(mm)	850
H2		(mm)	500
Ø A		(mm)	405
Fig. 423	DP34	H	(mm) 932
		PN16	(kg) approx. 544
	DP34T	H	(mm) 1149
		PN16	(kg) approx. 615

Standard-flange dimensions refer to page 15.

Face-to-face dimension FTF series 1 according to DIN EN 558-1

Parts

Pos.	Description	Fig. 22.423
1	Body	EN-GJS-400-18U-LT, EN-JS1049
2	Seat ring *	X20Cr13+QT, 1.4021+QT
3	Bottom flange	EN-GJS-400-18U-LT, EN-JS1049
5	Gasket *	Pure graphite (CrNi laminated with graphite)
6	Studs	25CrMo4, 1.7218
7	Hexagon nut	C35E, 1.1181
8	Plug *	X20Cr13+QT, 1.4021+QT
9	Straight pin *	X10CrNi18-8, 1.4310
10	Stem *	X20Cr13+QT, 1.4021+QT
12	Stuffing box housing	P250 GH, 1.0460
13	Guide bushing	X20Cr13+QT, 1.4021+QT (hardened)
17	Packing ring *	PTFE or Pure graphite
19	Washer *	X5CrNi18-10, 1.4301
20	Packing box flange	EN-GJS-400-18U-LT, EN-JS1049
21	Studs	25CrMo4, 1.7218
22	Hexagon nut	C35E, 1.1181
26	Hexagon nut	17H-A4G
34	Studs	25CrMo4, 1.7218
35	Hexagon nut	C35E, 1.1181
36	Gasket *	Pure graphite (CrNi laminated with graphite)

* Spare parts

Information / restriction of technical rules need to be observed!

A production allowance acc. to TRB 801 No. 45 exists

The engineer, designing a system or a plant, is responsible for the selection of the correct valve.

max. permissible closing pressures for both seat positions on flow-to-open P2 = 0 (Observe regulations, refer to page 15.)

Spring closes port A -> AB or Spring closes port B -> AB

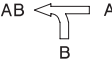
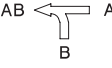
Mixing function		DN		300		
		Standard Kvs-values	Seat-Ø A/B (mm)		250	
			Kvs-value		1500	
			Travel (mm)		75	
		Reduced Kvs-values	Seat-Ø A/B (mm)	250		
			Kvs-value	1000		
			Travel (mm)	65		
Actuator DP34	Spring range (bar)	1,0 - 2,0	Air supply pressure min. (bar)	3,0	1,1	
				2,0 - 4,0	6,0	2,6
Actuator DP34T		0,55 - 2,4		3,0		1,2
		1,0 - 2,0		3,0	2,6 a)	
		2,0 - 4,0		6,0	5,8	
Air supply pressure max. of pneumatic actuators DP:		max. permissible	6 bar			
Air supply pressure max. limit of control valve:		max. permissible	a) 5 bar b) 4,5 bar c) 4 bar d) 3,5 bar e) 3 bar			

Standard-flange dimensions

Flanges acc. to DIN EN 1092-1/-2 (Flange holes / -thickness tolerances acc. to DIN 2533/2544/2545)

DN			300
PN16	ØD	(mm)	460
PN16	ØK	(mm)	410
PN16	n x Ød	(mm)	12 x 26

Pressure-temperature-ratings acc. to DIN EN 1092-2

Material			-10°C to 120°C	150°C	200°C	250°C	300°C	350°C
EN-JS1049	PN16	(bar)	16	15,5	14,7	13,9	12,8	11,2

Intermediate values for max. permissible operational pressures can be determined by linear interpolation of the given temperature / pressure chart.

Please indicate when ordering:

- Figure-No.
- Nominal diameter
- Nominal pressure
- Body material
- Plug design
- Kvs-value
- Stem sealing
- Actuator
- Special design / accessories

Example:

Figure 22.423, Nominal diameter DN300, Nominal pressure PN16, Body material EN-JS1049, Mixing construction, Kvs 1500, Stem sealing: Pure graphite-packing, with pneumatic actuator DP34.

 Dimensions in mm
 Weights in kg
 Pressures in barg (gauge)
 $1 \text{ bar} \hat{=} 10^5 \text{ Pa} \hat{=} 0,1 \text{ MPa}$
 Kvs in m³/h

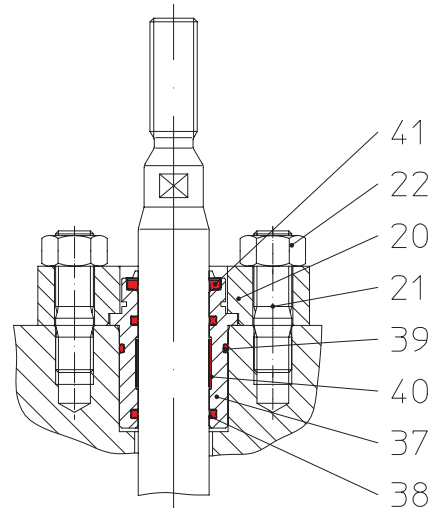
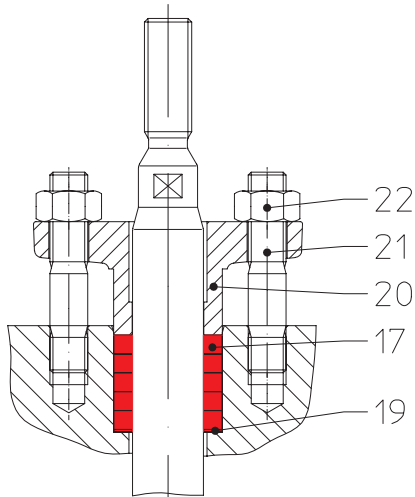
Stem sealing

Pos.	Description	
17	Packing ring *	PTFE or Pure graphite
19	Washer *	X5CrNi18-10, 1.4301
20	Packing box flange	EN-GJS-400-18U-LT, EN-JS1049
21	Studs	25CrMo4, 1.7218
22	Hexagon nut	C35E, 1.1181
* Spare parts		

PTFE- / gland packing

Pos.	Description	
20	Packing box flange	X10CrNi18-8, 1.4310
21	Studs	25CrMo4, 1.7218
22	Hexagon nut	C35E, 1.1181
37	Stem guiding *	X6CrNiMoTi17-12-2, 1.4571
38	Quadrang *	EPDM
39	O-ring *	EPDM
40	Strip *	PTFE +25%C
41	Scraper *	NBR
* Spare parts		

EPDM-Shut off class