

31300G

Butterfly valve of carbon steel DN 200 - 1400

11.02.2008

Operation

The welded butterfly valve 31300 with GOST weld ends is specially designed for district heating. It can be used as an on-off or control valve. Högfors butterfly valve is tight in both flow directions.

Nominal pressure 25 bar
Closing pressure difference 16 bar
Tightness class ISO 5208, EN 12266-1, RATE B
Operating temperature
 max +260°C/ min -40°C (DN200 - 1000)
 max +260°C/ min -20°C (DN1200 - 1400)

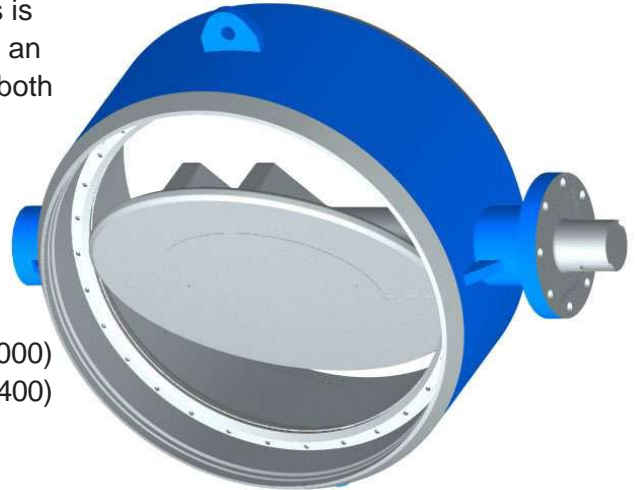

The max pressure difference depends on the working temperature

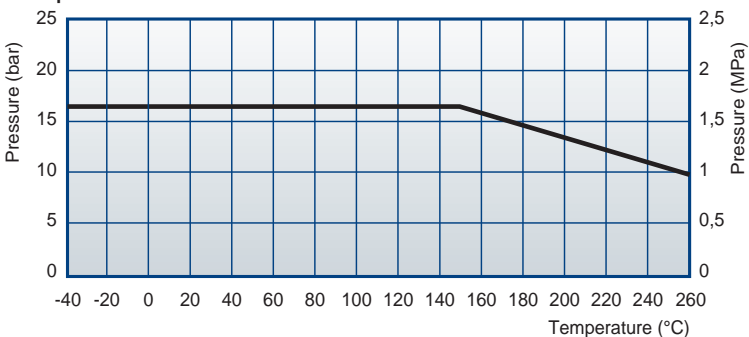

Construction

The body of the butterfly valve with GOST weld ends is carbon steel. The double eccentric disc and shafts are made of stainless steel. Replaceable seat ring is also stainless steel. The shaft packing box is a combination of graphite rings and O-rings which are possible to tighten and are also replaceable.

Face-to-face length: EN 558-1 series 14

Conform with the requirements of the Council Directive 97/23/EC on Pressure Equipment, marking:
Class: Gas, group 1



Nominal dimensions: DN 200 - 300

Product codes: 31300CS___Z with bare shaft
31300CS___M with manual gear

Nominal dimensions: DN 350 - 1400

Product codes: 31300CS___ZG with bare shaft
31300CS___MG with manual gear

For steam on special order. **Code number:** 31301CS

Materials

Body: Carbon steel EN 10028-2 P265GH
Disc: Stainless steel EN 10213-4 1.4408, ASTM A351 CF8M
Shaft: Stainless steel EN 10088-3 1.4460
Disc seal: Stainless steel
Shaft seal: Graphite/ EPDM

31300G Butterfly valve of carbon steel
DN 200 - 1400

11.02.2008

Dimensions

DN	L	D	D1	D2	s	h	H	h1	d1	h2	L1	Flange ISO5211
200	230	137,5	210,1	219,1	4,5	154	259	58	25	115	233	F10
250	250	187	263,0	273,0	5	193	298	63	30	125	385	F12
300	270	238	312,7	323,9	5,6	229	323	69	35	125	435	F12
350	290	286	365,0	377,0	6	255	352	75	40	125	465	F14
400	310	337	414,0	426,0	6	300	409	75	40	155	540	F14
500	350	437	516,0	530,0	7	351	470	86	50	163	660	F16
600	390	483	616,0	630,0	7	376	548	103	60	186	760	F16
700	430	582	704,0	720,0	8	440	601	119	70	186	860	F25
800	470	682	804,0	820,0	8	490	651	119	70	187	955	F30
900	510	775	902,0	920,0	9	575	718	125	90	200	1070	F30
1000	550	855	1000	1020	10	636	764	130	100	183	1200	F30
1200	630	1054	1195	1220	12,5	755	873	160	140	182	1440	F35
1400	710	1237	1392	1420	14	912	1018	180	170	206	1770	F40

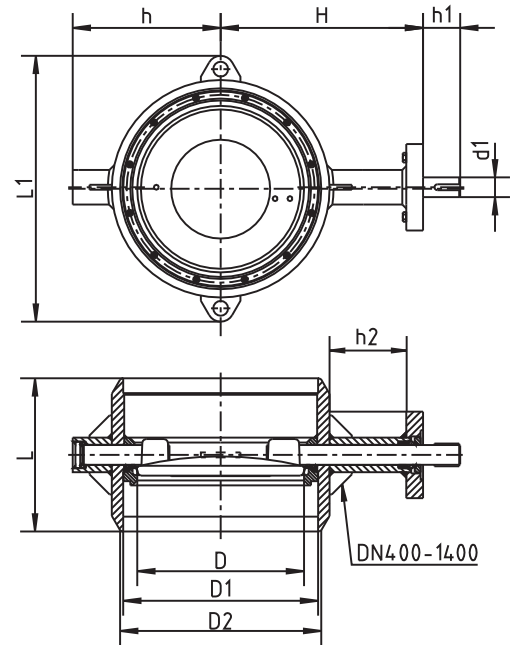
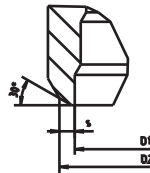

Operation

The butterfly valve is delivered with handlever, manual gear, electric, pneumatic or hydraulic actuator according to customer's needs.

Manual gear

Opening and closing of the valves from the handwheel.
The position of disc can be seen on a position indicator on top of the gear.

DN	H	h	a	b	c	d	Weight kg
200	349	154	202	67	301	203	50
250	379	193	247	67	340	305	57
300	417	229	264	90	373	305	70
350	446	255	264	90	402	305	107
400	503	300	264	90	459	305	131
500	576	351	362	123	520	457	219
600	675	376	387	154	598	457	350
700	761	440	505	181	687	457	485
800	811	490	505	181	737	457	574
900	887	575	592	237	792	457	975
1000	942	636	615	431	807	500	1290
1200	1051	755	615	431	962	600	2480
1400	1218	912	755	450	1158	700	3210

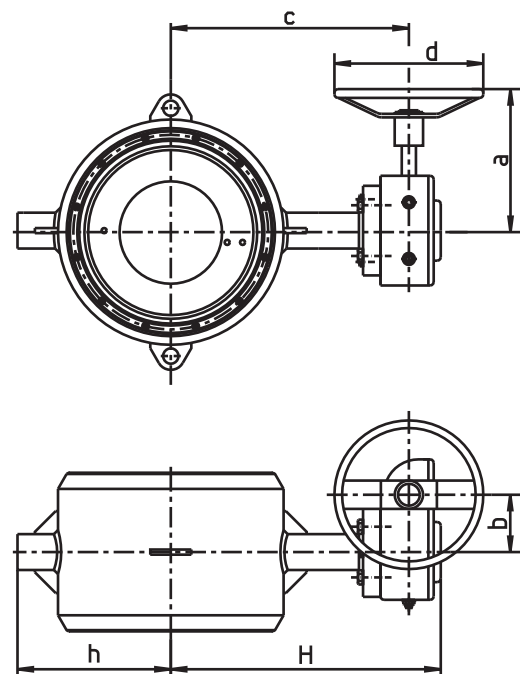

The control curves

The curves indicate the regulating values of the valve at different opening angles.

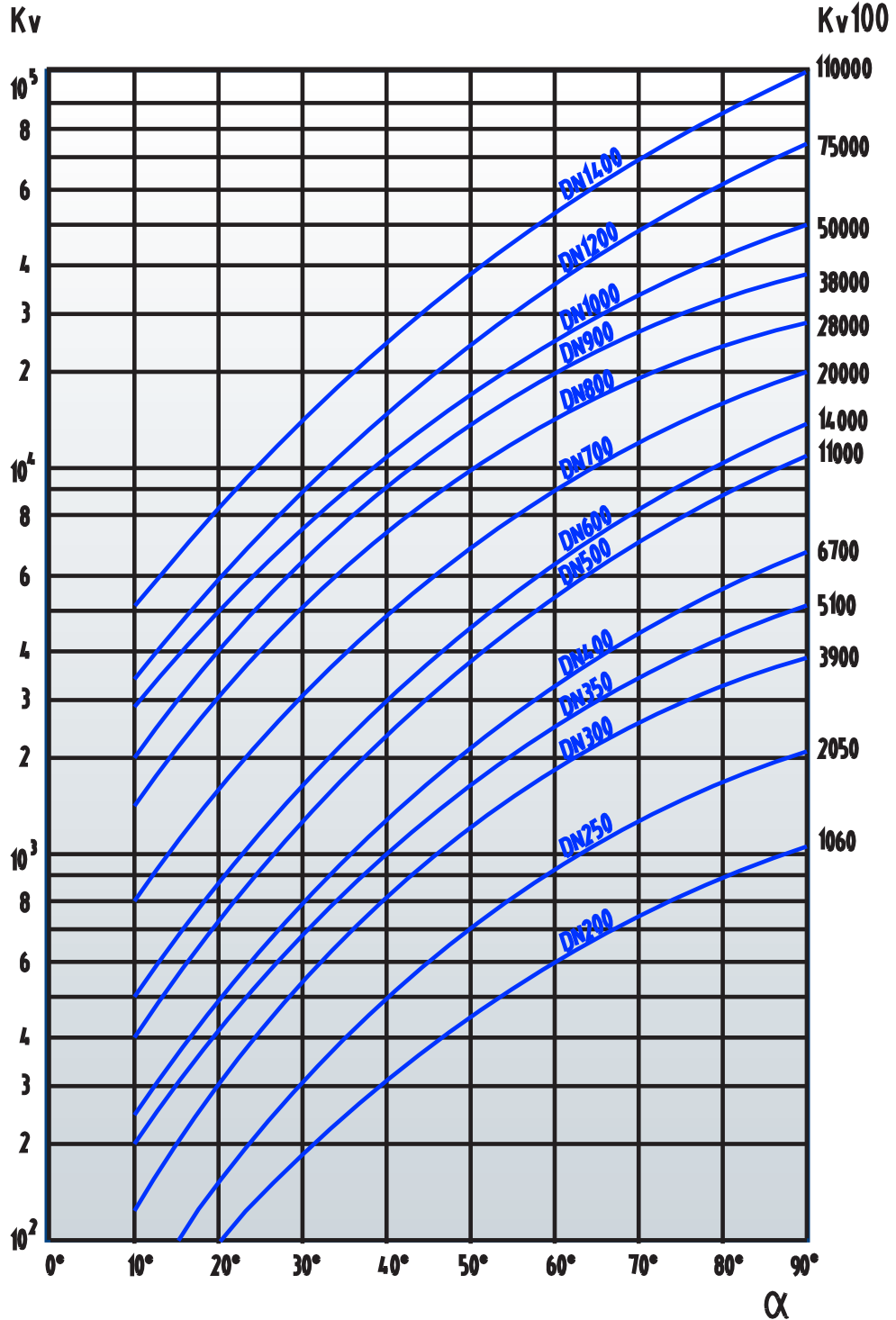

WATER:

Volume flow:

$$Q = K_v \sqrt{\frac{\Delta p}{\rho}}$$

Flow velocity:

$$v = 354 \frac{Q}{DN^2}$$

K_v
DN
 α
Q
 Δp
 ρ
v

= kv-value — Capacity factors
= nominal valve size (mm)
= disc opening angle
= volume flow m^3/h
= pressure difference bar
= density of liquid kg/dm^3
= flow velocity m/s