

# D71

**D71 118 616.11 Strainer flanged**  
PN16

## CAST IRON Y STRAINER FLANGED PN 10/16



**Size :** DN 15 to DN 400  
**Ends :** Flanges R.F. PN10/16  
**Min Temperature :** - 10°C  
**Max Temperature :** + 120°C  
**Max Pressure :** 16 Bars up to DN 200 ( 10 bars over )  
**Specifications :** Removable stainless steel filter  
Bolted bonnet with draining cap

**Materials :** Cast iron body EN GJL-250

# D71

## D71 118 616.11 Strainer flanged PN16

### CAST IRON Y STRAINER FLANGED PN 10/16

#### SPECIFICATIONS :

- Removable stainless steel filter
- R.F. flanges PN10/16
- Horizontal or vertical position with descendant fluid (respect the flow direction indicated by the arrow )
- Mesh 1.1mm from DN 15 to 125, 1.5 mm from DN 150 to 300 and 3 mm from DN 350 to 400
- Bolted bonnet with draining cap threaded BSP
- Epoxy painting RAL 7011 color, 150µm thickness

#### USE :

- For water, water treatment, irrigation
- Min Temperature Ts : - 10°C
- Max Temperature Ts :+ 120°C
- Max Pressure Ps : 16 bars at 120°C up to DN200 , 10 bars over

#### HEAD LOSS GRAPH DN15-300 :

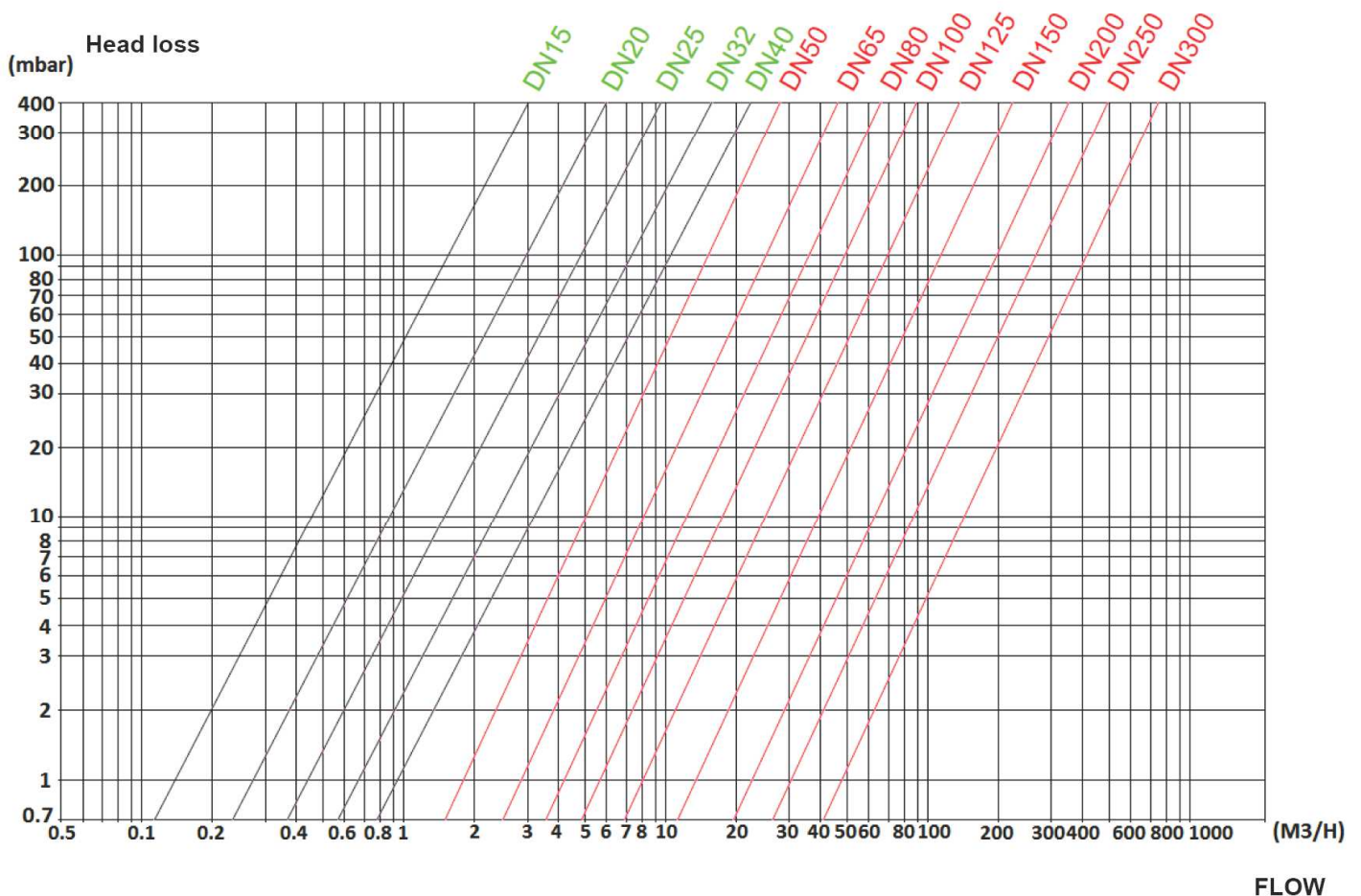

# D71

D71 118 616.11 Strainer flanged  
PN16

## CAST IRON Y STRAINER FLANGED PN 10/16

HEAD LOSS GRAPH DN350-400 :

Head loss (mbar)

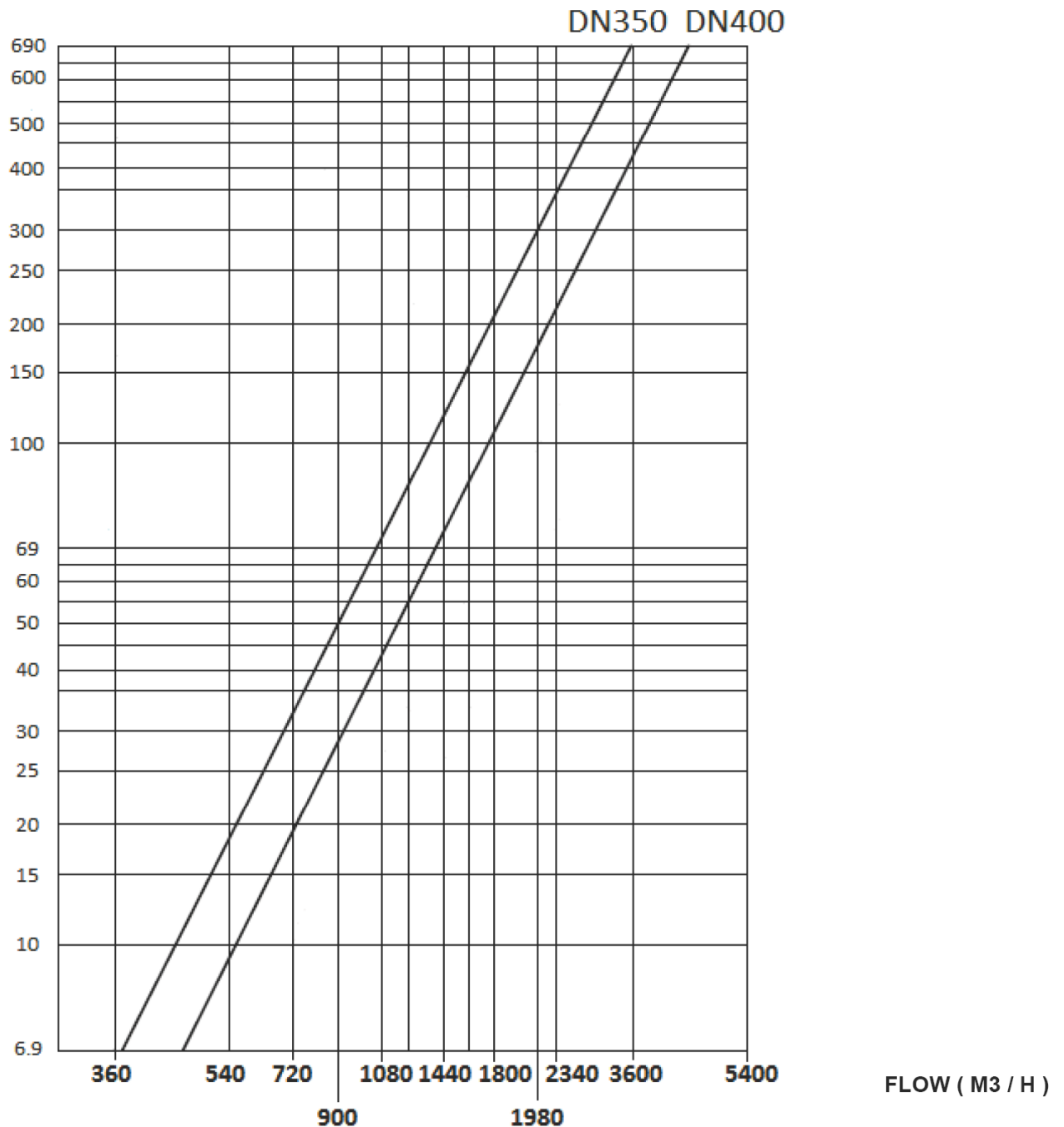

# D71

## D71 118 616.11 Strainer flanged PN16

### CAST IRON Y STRAINER FLANGED PN 10/16

#### RANGE :

- R.F. flanges PN10/16 from DN 15 to 400

#### MATERIALS :

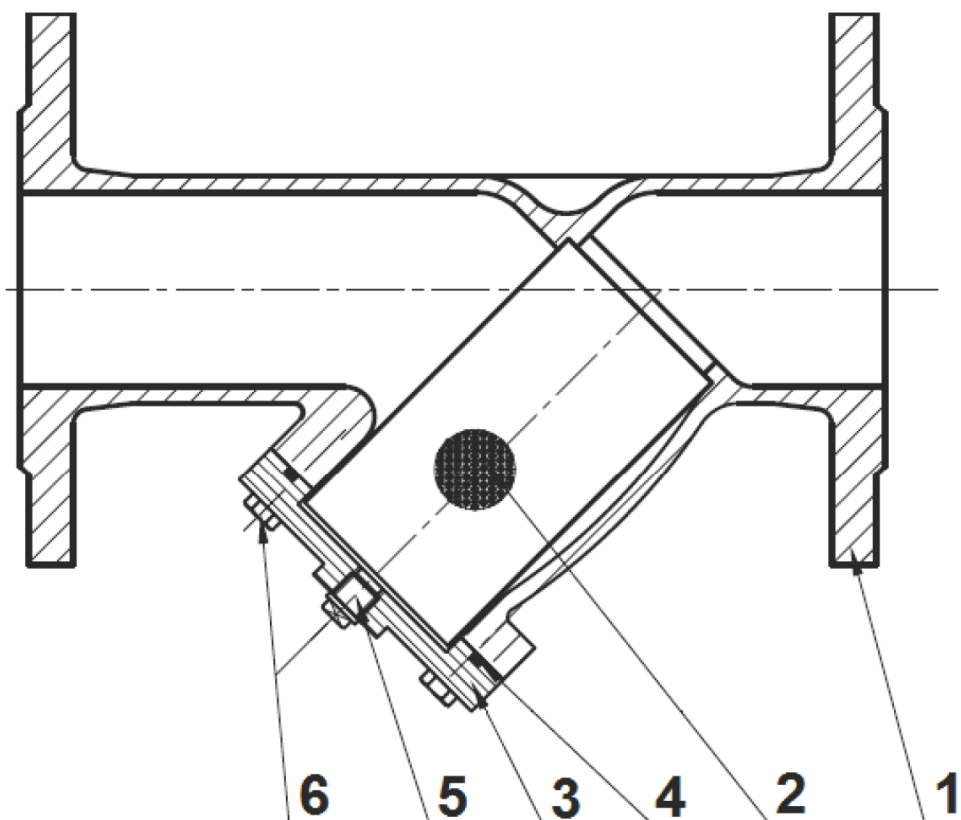

Item	Designation	Materials
1	Body	Cast iron EN GJL-250
2	Filter	SS 304
3	Bonnet	Cast iron EN GJL-250
4	Bonnet gasket	Graphite + SS304
5	Draining cap	Brass
6	Bonnet screw	SS 201

# D71

## D71 118 616.11 Strainer flanged PN16

### CAST IRON Y STRAINER FLANGED PN 10/16

SIZE ( in mm ) :

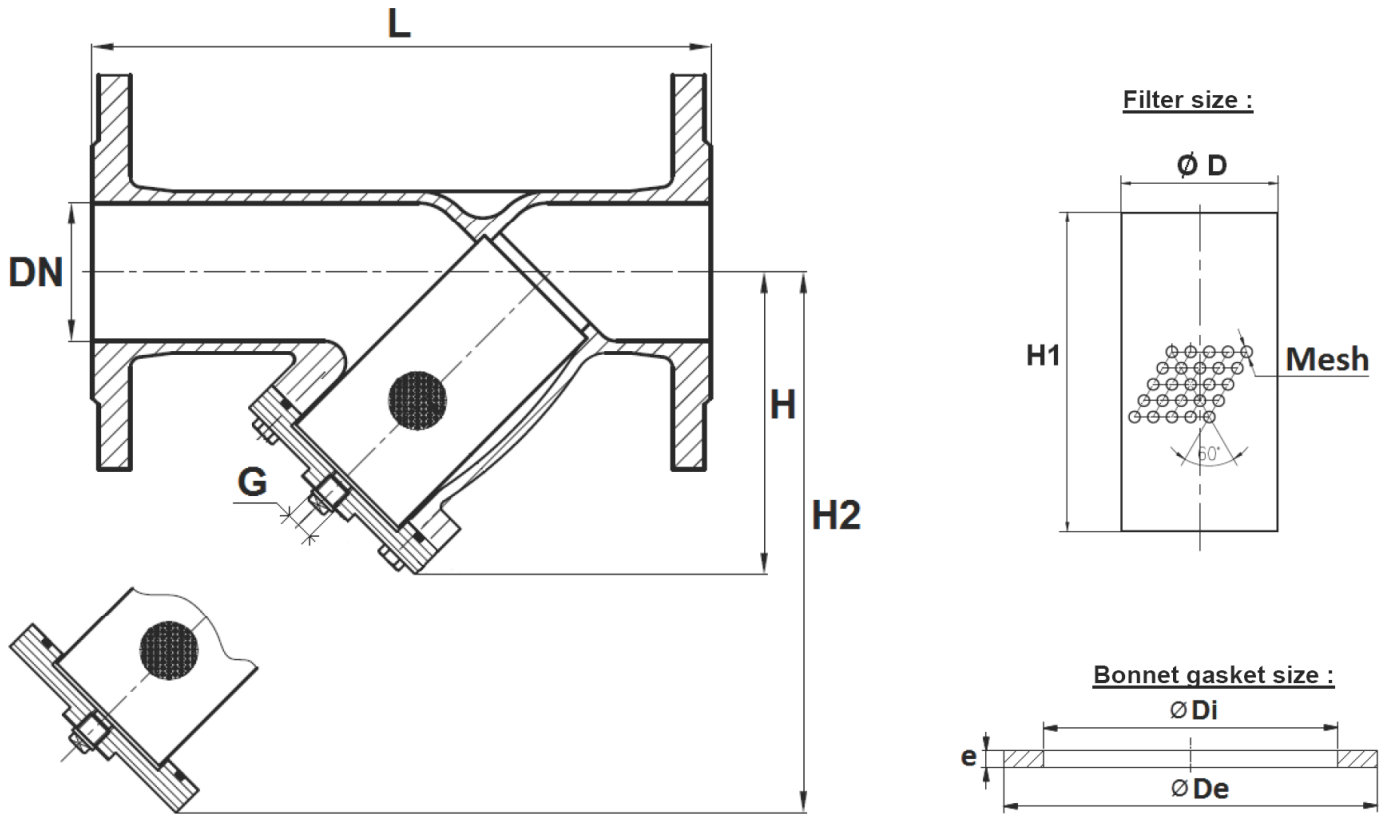

DN	15	20	25	32	40	50	65	80	100	125	150	200	250	300	350	400
L	130	150	160	180	200	230	290	310	350	400	480	600	730	850	980	1100
H	80	91	105	124	110	117	142	163	194	248	280	346	433	480	650	854
H2	130	146	175	210	175	192	232	265	323	402	430	560	715	785	1100	1420
G ( drain )	1/4"	1/4"	1/2"	1/2"	1/2"	1/2"	1/2"	1/2"	1/2"	1/2"	3/4"	3/4"	3/4"	3/4"	1/2"	1/2"
Ø D	17	23	27	35	42	52	67	82	102	127	160	206	252	302	353	403
H1	69	77.5	97	119.5	91.2	105.2	127.2	140.7	180.2	215.7	234.2	296.5	393.5	426	540	650
Mesh	1.1	1.1	1.1	1.1	1.1	1.1	1.1	1.1	1.1	1.1	1.5	1.5	1.5	1.5	3	3
Ø De	25	30	30	37	45	61	77	90	110	139	160	210	260	310	-	-
Ø Di	37	42	47	54	62	72	97	102	123	158	184	234	285	335	-	-
e	3.6	3.6	3.6	3.6	3.6	3.6	3.6	3.6	3.6	3.6	3.6	3.6	3.6	3.6	-	-
Weight ( Kg )	2.3	3	3.8	5.1	6.3	7.7	11.4	14.2	18.5	28.5	39.2	61.2	115.6	155.5	264	462

# D71

## D71 118 616.11 Strainer flanged PN16

### CAST IRON Y STRAINER FLANGED PN 10/16

FLANGES SIZE PN10 (in mm) :

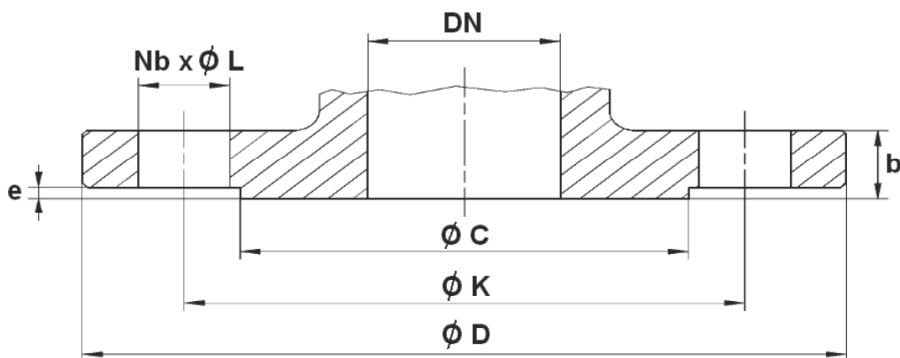

DN	15	20	25	32	40	50	65	80	100
Ø C	45	58	68	78	84	99	118	132	156
Ø D	95	105	115	140	150	165	185	200	220
Ø K	65	75	85	100	110	125	145	160	180
Nb x Ø L	4 x 14	4 x 14	4 x 14	4 x 19	4 x 19	4 x 19	4 x 19	8 x 19	8 x 19
b	16	18	18	18	19	19	19	19	19
e	2	2	2	2	3	3	3	3	3
Ref.	220015	220020	220025	220032	220040	220050	220065	220080	220100

DN	125	150	200	250	300	350	400
Ø C	184	211	266	319	370	430	482
Ø D	250	285	340	395	445	505	565
Ø K	210	240	295	350	400	460	515
Nb x Ø L	8 x 19	8 x 23	8 x 23	12 x 23	12 x 23	16 x 23	16 x 28
b	19	19	20	22	24.5	26.5	28
e	3	3	3	3	4	4	4
Ref.	220125	220150	220201	220250	220300	220350	220400

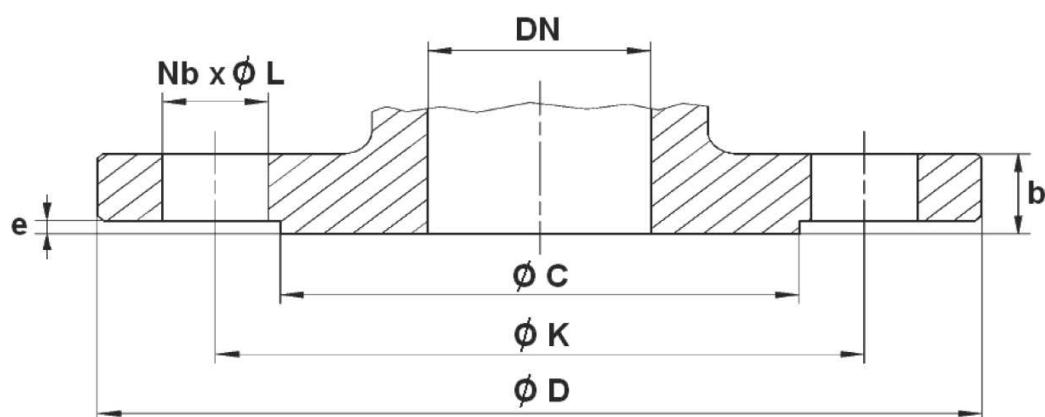
**D71****D71 118 616.11 Strainer flanged  
PN16****CAST IRON Y STRAINER FLANGED PN 10/16**FLANGES SIZE PN16 ( in mm ) :

DN	200	250	300
Ø C	266	319	370
Ø D	340	405	460
Ø K	295	355	410
Nb x Ø L	12 x 23	12 x 28	12 x 28
b	28	30	32
e	3	3	4
Ref.	220200	220251	220301

# D71

**D71 118 616.11 Strainer flanged**  
PN16

## CAST IRON Y STRAINER FLANGED PN 10/16

### STANDARDS :

- Fabrication according to ISO 9001 : 2008
- DIRECTIVE 97/23/CE : Products excluded (article 1, § 3.2)
- Pressure tests according to EN 12266-1
- Length according to EN 558 series 1 (DIN 3202 F1 – NF 29354)
- R.F. flanges according to EN 1092-2 PN10/16

### INSTALLATION POSITIONS :

Vertical position ( descendand fluid )



Horizontal position





# D71

**D71 118 616.11 Strainer flanged**  
PN16

## **CAST IRON Y STRAINER FLANGED PN 10/16**

### **INSTALLATION INSTRUCTIONS**

#### **GENERAL GUIDELINES :**

- Ensure that the strainers to be used are appropriate for the conditions of the installation (type of fluid, pressure and temperature).
- Be sure to have enough valves to be able to isolate the sections of piping as well as the appropriate equipment for maintenance and repair.
- Ensure that the strainers to be installed are of correct strength to be able to support the capacity of their usage.
- **Installation of all circuits should ensure that their function can be automatically tested on a regular basis (at least two times a year).**

#### **INSTALLATION INSTRUCTIONS :**

- **Before installing the strainers, clean and remove any objects from the pipes** (in particular bits of sealing and metal) which could obstruct and block the strainers.
- **Ensure that both connecting pipes either side of the strainer (upstream and downstream) are aligned** (if they're not, the strainer may not work correctly).
- **Make sure that the two sections of the pipe (upstream and downstream) match, the strainer unit will not absorb any gaps. Any distortions in the pipes may affect the tightness of the connection, the working of the strainer and can even cause a rupture.** To be sure, place the kit in position to ensure the assembling will work.
- Make sure flanges are cleaned.
- **If sections of piping do not have their final support in place, they should be temporarily fixed. This is to avoid unnecessary strain on the strainer.**
- Tighten the bolts in cross.
- The pressurisation must be increased gradually.
- So that the maintenance operations could be easily done, place a stop valve before and after the strainer. Thereby, the strainer could be isolated. During this operation, ensure to have a new bonnet gasket to avoid a leakage during the restarting.
- **Fluids in the strainer must not contain solid objects ( it could damaged the seat ).**