

BRONZE PRESSURE REDUCING VALVE TYPE 681

FEATURES

The pressure reducing valve 681 is intended for the function of reduction of the pressure on the supply systems of water or compressed air. Its heavy conception allows to use it on numerous applications in the industry. The downstream pressure stability is very good even with strong variations of upstream pressure. The 681 reducer is equipped with an internal strainer of protection. He must be used only on clean fluids. It is approved for a use on the drinking water. It has two pressure gauges indicating the upstream and downstream pressures.

AVAILABLE MODELS

681-F (female/female) : DN15 to DN25.

BSP Screwed end connections G/F.

681-M (mâle/mâle) : DN15 to DN50.

BSP Thread end connections G/M + unions fittings G M/F.

Manometer ø 50

LIMITS OF USE

Max allowed fluid pressure : PS	25 bar
Upstream pressure :	1 - 8 bar
Max allowed fluid temperature : TS	-10°C / +95°C

CONSTRUCTION

Item	Material
Body	Bronze CC 499K
Bonnet	Bronze CC 499K
Internal mechanism	Bronze CC 499K Brass CW 614N Stainless steel 1.4571
Spring	Spring steel 1.1200
Strainer of protection	Stainless steel 1.4301
Diaphragm	EPDM



REGULATIONS AND STANDARDS OF CONSTRUCTIONS

Item	Standard	Item	Standard
Pressure equipment directive 2014/68	DN15 to DN25 : excluded	Use on drinking water	ACS
	DN32 to DN50 : catégorie I		DVGW
Pressure reducing valve	EN 1567		WRAS

RV

RV682 PN25 DN25

Ventil redukční s manometrem

BRONZE PRESSURE REDUCING VALVE TYPE 681

Kv VALUES AND FLOWRATE DIAGRAM

DN 681-M	15	20	25	32	40	50
DN 681-F	15	20	25	X		
Kv (m ³ /h)	2,5 – 3,3	3,6 – 4,5	6,2 – 7,8	8,7 – 9,6	12 - 14	14,5 - 19
Maximum flowrate (m ³ /h)	7	9	16	18	30	35

Flowrate diagram / pressure loss ΔP for water

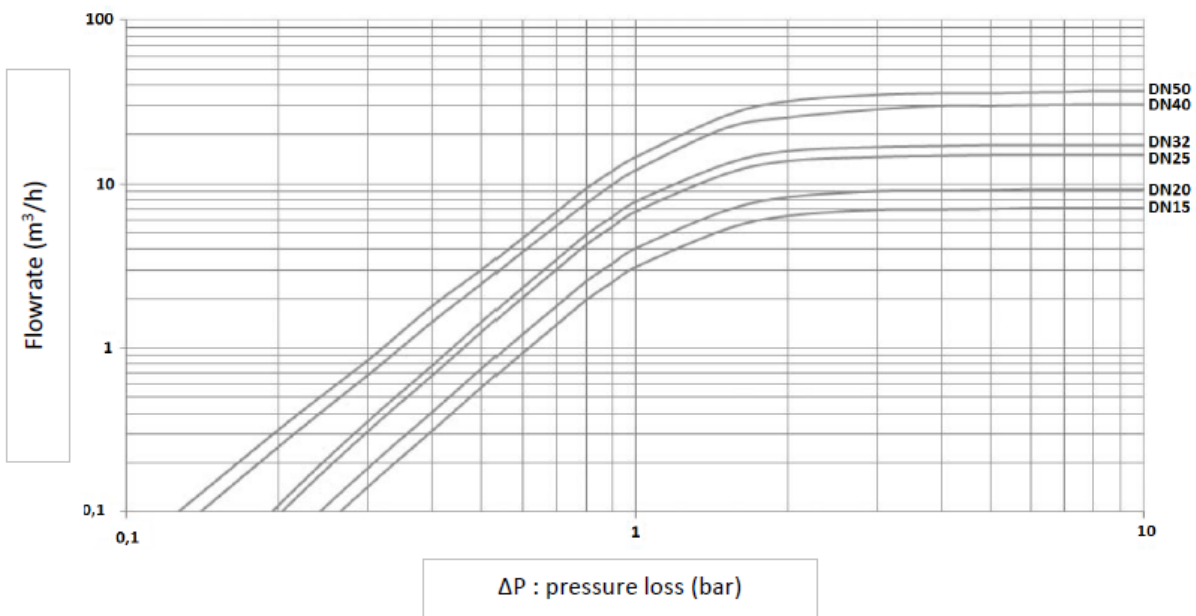

Other sizing's diagram : method of the speed

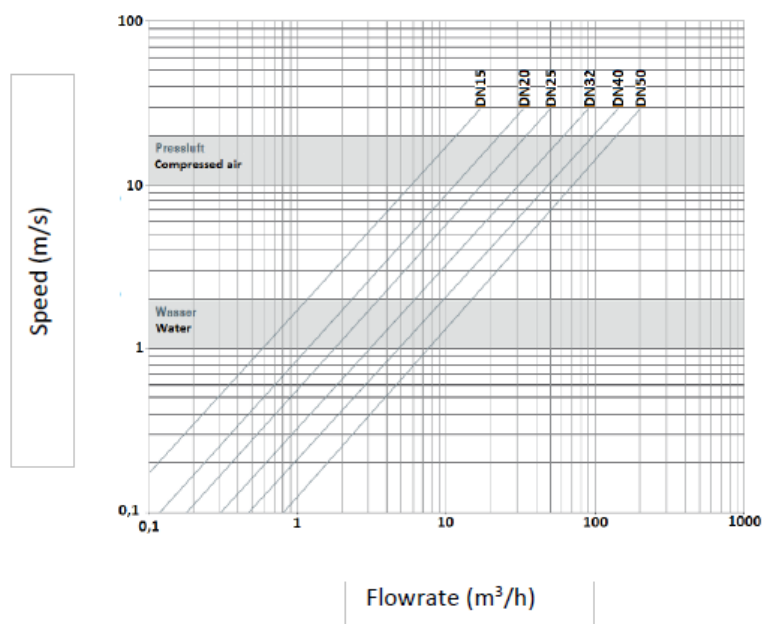

For the water or similar liquids, do not exceed the speed of 2 m/s.

For compressed air, choose a speed between 10 and 20 m/s

BRONZE PRESSURE REDUCING VALVE TYPE 681

DIMENSIONS (mm) AND WEIGHT (kg)

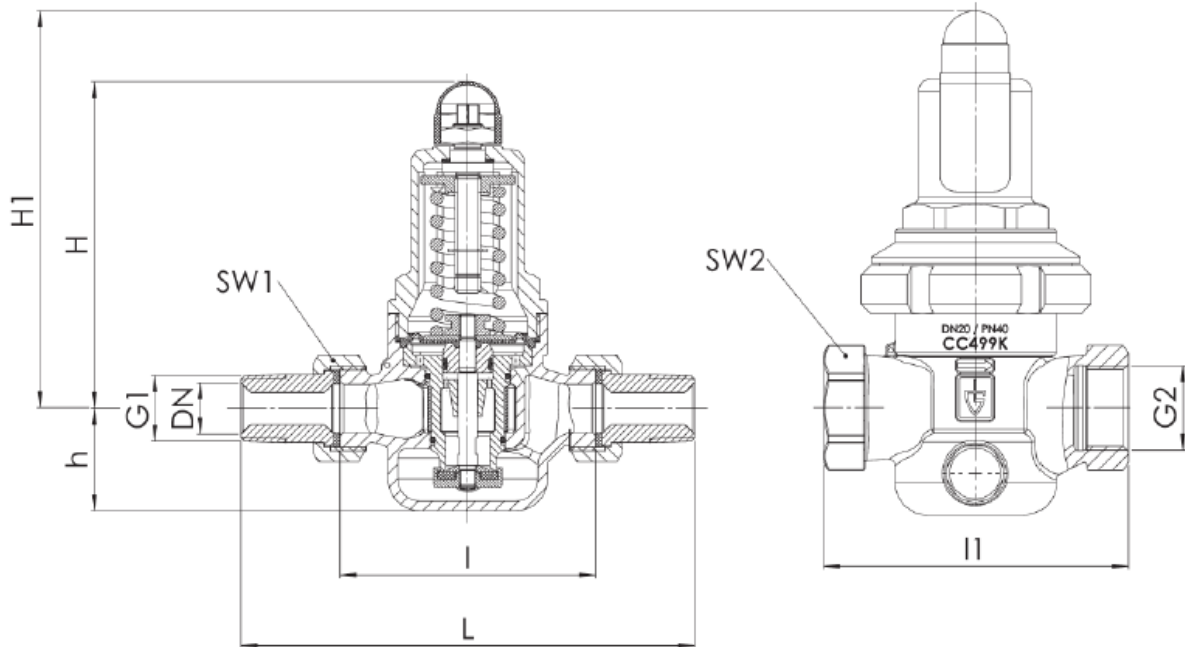

DN	G1	G2	L	l	H	H1*	h	l1	Weight 681-M	Weight 681-F
15	1/2"	1/2"	142	80	102	128	33	85	1,2	1,5
20	3/4"	3/4"	158	90	102	128	33	95	1,3	1,6
25	1"	1"	180	100	130	150	45	105	2,4	2,9
32	1"1/4	1"1/4	193	105	130	150	45		2,6	
40	1"1/2	1"1/2	226	130	165	185	70		5,5	
50	2"	2"	252	140	165	185	70		6,0	

* Low-pressure model

Pressure intake hole : G 1/4"

Internal strainer : thresholds of filtration

DN	Threshold (mm)
DN15 to DN32	0,6
DN40 to DN50	0,75

OPTIONS

Diaphragm in FKM

Upstream pressure until 30 bar and downstream 5 - 15 bar

Upstream pressure until 25 bar and downstream 0,5 - 2 bar

BRONZE PRESSURE REDUCING VALVE TYPE 681

INSTALLATION

Position of mounting : The pressure reducer 681 can be installed any position.

Sense of flow : Take care of the sense of mounting indicated by the arrow on the body.

Convergent and divergent : If the diameter of 681 is lower than the diameter of the piping, install upstream a convergent. For a use on a gas, It is necessary to plan at the exit of 681 a bigger sized pipe than that of the entrance and to connect it with a divergent, the lower pressure gas needing a bigger pipe's section.

Straight piping length : To assure a good stability of the downstream pressure and reduce the turbulences at the exit of the 681, plan before any of accident piping or device, a straight piping length at least equal to 5 x DN and 10 x DN if possible. In the case of a double pressure reduction, plan an identical length between both valves.

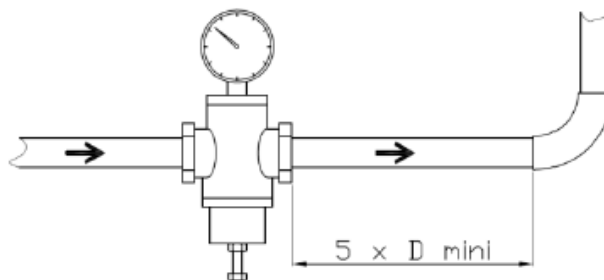

Upstream isolation : Plan a stop valve upstream to the 681. This one is not necessarily tight in zero flowrate and cannot be considered as an isolating valve.